

AGENDA

REDWOOD COUNTY BOARD OF COMMISSIONERS

Redwood County is committed to stewardship, respect & shared responsibility in providing improved cost-efficient services to all!

TUESDAY NOVEMBER 30, 2021

COMMISSIONERS' ROOM, GOVERNMENT CENTER

REDWOOD FALLS, MINNESOTA

Please Note: This agenda is subject to change due to Department Heads, government agencies and the public bringing items forward, between the posting of the agenda and the actual meeting time. **All times listed below are approximate.**

4:00 p.m.

- Open Forum**
- Review and approve November 30th Meeting Agenda
- Identification of Conflict of Interest
- Review and approve Consent Agenda:
- November 16th minutes

4:00 p.m.

- **ROAD AND BRIDGE**
Anthony Sellner
 - 1) Authorization to Pay Bills
 - 2) Horseshoe Lake Project

4:30 p.m.

- **TECHNOLOGY**
Paul Parsons
 - 1) Computer Purchase

4:35 p.m.

- **ECONOMIC DEVELOPMENT**
Briana Mumme
 - 1) Small Cities CDBG-CV Broadband Grant Award

4:50 p.m.

- **AUDITOR/TRESURER**
Jean Price
 - 1) Resolution Approving Redwood County's Application for Funding from the 2021 Voting Equipment Grant (VEGA-3)

5:00 p.m.

- **ADMINISTRATOR**
 - 1) 2022 Grandview Winery Liquor License
 - 2) Alpha Media (KLGR) Lease Agreement
 - 3) Area II Joint Powers Agreement

Other Items – No Scheduled Time:

Commissioner Items:

6:00 p.m.

➤ **TRUTH IN TAXATION MEETING**

- 1) Resolution Setting 2022 Tax Levy
- 2) Resolution Adopting 2022 Budget

ADJOURN

****OPEN FORUM****

OPEN FORUM PROCEDURES

1. The open forum will be held at the beginning of the meeting.
2. Those wishing to speak should sign up and indicate the topic at the beginning of the meeting.
3. A maximum time of 20 minutes will be allowed for the open forum.
4. A basic guide of three people per topic with a maximum of five minutes per person.
5. Those speaking will state their name and address prior to speaking.
6. Statements should be limited to the issues only.
7. Apply the “Golden Rule” during presentations.
8. The Board retains the right to respond or not, but may discuss the item.
9. Personal/Personnel issues will not be heard or discussed.

REDWOOD COUNTY, MINNESOTA

NOVEMBER 16, 2021

The Board of County Commissioners met in regular session at 8:30 a.m. in the Commissioners' Room in the Government Center, Redwood Falls, Minnesota.

Present for all or portions of the meeting were Commissioners Bob Van Hee, Dave Forkrud, Jim Salfer, Dennis Groebner and County Administrator Vicki Kletscher. Also present were Auditor/Treasurer Jean Price; Recorder Joyce Anderson; Technology Coordinator Paul Parsons, Human Resource Coordinator Peter Brown; Economic Development Coordinator Briana Mumme; Environmental Director Scott Wold; Planning and Zoning Supervisor Nick Brozek; Highway Engineer Anthony Sellner; Highway Maintenance Supervisor Jamie Larsen; County Attorney Jenna Peterson; Sheriff Randy Hanson; Jesse Jacobson; Contegrity Group Representative Larry Filippi and WOLD Architect John McNamara, Vicki Friedrich and Greg Knight. Commissioner Rick Wakefield was absent.

Chair Salfer called the meeting to order asking for the Pledge of Allegiance to the Flag.

On motion by Groebner, second by Van Hee, the Board voted unanimously to approve the revised November 16th agenda.

Chair Salfer asked the Board members to identify any areas for which they had a Conflict of Interest. There were none.

CONSENT AGENDA

- On motion by Forkrud, second by Groebner, the Board voted unanimously to approve the Consent Agenda.
 - November 2nd, 2021 Board Minutes
 - Payment of bills as follows:

General Fund	\$ 116,084.37
Ditch Maintenance Fund	\$ 7,779.11
Insurance Fund	\$ 327.40
Building Fund	\$ 10,569.48
Solid Waste Fund	\$ 3,748.49
Soil and Water Fund	\$ 2,903.20
Road and Bridge Fund	\$ 22,505.25
Debt Service Fund	\$ 39,145.97

- Bills over \$2,000: Henle Printing Company \$4,750.34; Counties Providing Technology \$3,892.00; Carris Health \$6,185.51; Nobles County \$2,625.00; Renville County \$32,720.25; Fleet Services \$7,476.62; Mend Correctional Care \$12,128.49; Redwood County Highway Department \$4,023.72; Tersteeg's Holiday Market \$7,605.97; Geo-Comm \$4,850.00; Peterson Company \$3,175.00; One Office Solution

\$3,821.65; Minnesota Pollution Control \$5,311.05; Baker Tilly \$22,302.25,
\$2,783.85; \$39,145.97; WOLD Architects \$10,569.48; TNT Construction \$5,940.00;
Eric Fultz \$2,088.45

EMPLOYEE RECOGNITION

- The Board recognized Mark Cook, Sheriff's Department, for 10 years of service to Redwood County.

ROAD AND BRIDGE

- Sellner presented information on the Horseshoe Lake Project. Chair Salfer tabled discussion to the November 30, 2021 board meeting.
- On motion by Forkrud, second by Van Hee, the Board voted unanimously to approve the NASPO ValuePoint State of Minnesota FMV Lease Agreement for the postage machine at the Highway Department pending County Attorney approval.
- On motion by Forkrud, second by Groebner, in a 3-1 vote with Salfer voting nay, the Board voted to approve the purchase a snowplow truck from Truck Center Companies in the amount of \$125,201.00 off State Contract #194867.
- Sellner presented information regarding township bridge inspections and costs incurred by the Redwood County Highway Department.

AUDITOR/TREASURER

- On motion by Van Hee, second by Groebner, the Board voted unanimously to approve the following:
 - Cash Balance Report
 - Investment Summary
 - Budget Reports, General Fund, Road and Bridge Fund, Health Fund, Debt Service Fund, Building Fund, Ditch Maintenance, Human Services Fund, Insurance Fund, Soil and Water Conservation District Fund and Solid Waste Fund.
 - October 2021 Disbursements in the amount of \$5,167,633.51.
 - Bills totaling \$2,000: Redwood Electric Coop \$2,539.10; Redwood Falls Public Utilities \$9,470.05; Further \$8,044.24, \$8,044.24; Preferred One \$11,244.81, 9,434.28, \$8,653.70, \$7,757.50, \$27,421.92, 20,147.37, \$17,333.56, \$18,895.11; BCBS \$2,218.50; MN Commission of Finance \$406,862.31, \$5,178.50; Wells Fargo Advisors \$1,000,000.00, \$1,000,000.00; Minnesota Department of Revenue \$32,262.85; US Postal Service \$3,000.00; Redwood County License Center \$2,710.00, \$5,350.85, \$2,276.16; Gary Kerkhoff Construction \$9,245.73; Great Plains Natural Gas \$27,751.69, \$27,698.00; Northern Natural Gas Company \$19,479.63; Southpoint Financial Credit Union \$2,589.02; Redwood Soil and Water \$4,999.50; Sun Life Financial \$2,138.58; Diane Chapman \$5,483.33; Richard Cool \$3,640.00, \$3,640.00; Delta Dental \$4,015.06; Fagen Farms \$17,500.00; John Hansvick \$10,815.00; Vicki Hoffmann \$6,020.00; Robert Huhnerkoch \$10,710.00; Vicki Huhnerkoch \$15,210.00; James Milbradt Trust \$3,500.00; Gail & Paul Klause \$10,500.00; Terry Lecy \$5,483.34; Leo Mertens Revocable Living Trust \$7,000.00; Todd Mertens \$7,000.00; Lee Potzler \$2,310.00; Joel & Jolene Samyn \$5,950.00; Harry Schaffran Trust \$5,483.33; Faye Schmidt \$8,400.00; Robert Vanderlinden \$2,000.00; SD 2190 \$4,124.16; SD 2754 \$122,949.15; SD 2884 \$81,789.46; SD 2897 \$626,119.88; SD

2898 \$106,312.29; SD 2904 \$15,148.94; SD 635 \$74,887.02; SD 640 \$162,053.72; SD 85 \$18,865.61; Blackstrap \$7,166.23, \$28,519.08; Farmward Cooperative \$13,900.00; Traffic Marking Service \$27,453.81; Duinink Inc. \$168,658.18; R & G Construction \$845,270.70.

- On motion by Groebner, second by Salfer, the Board voted unanimously to approve the 2021 Tax Forfeited Administrative Charges per MN Statute 282.09 in the amount of \$10,251.04 to be paid from the 10-26-21 tax forfeited sale proceeds first.

ECONOMIC DEVELOPMENT

- Chair Salfer appointed Jeff Manthei to serve as the Redwood County Economic Development Authority District 5 board member, effective January 1, 2022.
- On motion by Van Hee, second by Salfer, the Board voted unanimously to approve the Economic Development Authority revolving loan to Kyle Pankonin, DBA Red Rock Chiropractice, in the amount of \$50,000.00 at a 5% fixed interest rate over a 10 year term.
- Discussion held regarding the Small Cities CDBG-CV Broadband Grant Award in the amount of \$1,715,607.00 for a broadband project within the City of Sanborn and Charlestown Township. Options regarding the acceptance of the grant were discussed. On motion by Van Hee, second by Salfer, in a 2-2 vote, with Groebner and Forkrud voting nay, the motion to accept the grant award, issue a RFP for the environmental assessment and a second RFP for the ISP and Engineering Firm with an anticipated cost of \$40,000.00 failed. Chair Salfer requested further discussion be held at the 11-30-21 board meeting.

PLANNING AND ZONING

- An application for rezoning #1-21R was filed by David Swantek of the Minnesota Department of Veterans Affairs for the rezoning of the southern part of the Veterans Cemetery property from Agriculture District to Urban Expansion District on the following described real property: situated in the County of Redwood, State of Minnesota, to wit: 4.2 acre tract in the NW ¼ of the SE ¼ and a 14.7 acre tract in the NE ¼ of the SE ¼ and the East 70 acres of the NE Fractional ¼, except a 395'x583' tract and except a tract to MNDOT, 81.49 acres, Twp 112, Range 35, Paxton Township. On motion by Groebner, second by Forkrud, the Board voted unanimously to approve Rezoning Permit #1-21R.
- An application for a Conditional Use Permit #14-21 was filed by Vicki Friedrich for a Country Music and Camping festival to be held on the following described real property: situated in the County of Redwood, State of Minnesota, to wit: N 1040' of the E 420' of the E ½ of the NW ¼ of Section 21, Twp. 113N, Range 36W, Delhi Township. On motion by Forkrud, second by Van Hee, in a 3-1 vote with Salfer voting nay, the Board voted to approve CUP #14-21.

JUSTICE CENTER CONSTRUCTION UPDATE

- Wold and Filippi presented a progress and budget report on the Justice Center. A Board tour was provided at the end of the meeting.

SHERIFF

- The Board reviewed the October Jail Population and Sentence to Serve quarterly report.

SHERIFF AND COUNTY ATTORNEY

- On motion by Forkrud, second by Groebner, the Board voted unanimously to approve the State of Minnesota Joint Powers Agreement on behalf of its Sheriff.
- On motion by Van Hee, second by Forkrud, the Board voted unanimously to approve the Court Data Services Subscriber Amendment to CJDN Subscriber Agreement for the Sheriff and the County Attorney.
- On motion by Van Hee, second by Forkrud, the Board voted unanimously to approve the State of Minnesota Joint Powers Agreement on behalf of its County Attorney.
- On motion by Forkrud, second by Groebner, in a roll-call vote with Forkrud, Groebner, Van Hee and Salfer all voting aye, the Board adopted the following resolution:

**RESOLUTION APPROVING STATE OF MINNESOTA JOINT POWERS AGREEMENTS
WITH THE COUNTY OF REDWOOD
ON BEHALF OF ITS COUNTY ATTORNEY AND SHERIFF**

WHEREAS, the County of Redwood on behalf of its County Attorney and Sheriff desires to enter into Joint Powers Agreements with the State of Minnesota, Department of Public Safety, Bureau of Criminal Apprehension to use systems and tools available over the State's criminal justice data communications network for which the County is eligible. The Joint Powers Agreements further provide the County with the ability to add, modify and delete connectivity, systems and tools over the five year life of the agreement and obligates the County to pay the costs for the network connection.

NOW, THEREFORE, BE IT RESOLVED by the County Board of Redwood, Minnesota as follows:

1. That the State of Minnesota Joint Powers Agreements by and between the State of Minnesota acting through its Department of Public Safety, Bureau of Criminal Apprehension and the County of Redwood on behalf of its County Attorney and Sheriff are hereby approved.
2. That the Sheriff, Randy Hanson, or his or her successor, is designated the Authorized Representative for the Sheriff. The Authorized Representative is also authorized to sign any subsequent amendment or agreement that may be required by the State of Minnesota to maintain the County's connection to the systems and tools offered by the State.
3. That the County Attorney, Jenna M. Peterson, or his or her successor, is designated the Authorized Representative for the County Attorney. The Authorized Representative is also authorized to sign any subsequent amendment or agreement that may be required by the State of Minnesota to maintain the County's connection to the systems and tools offered by the State.
4. That James Salfer, the Chair of the County of Redwood, and Vicki Kletscher, the County Board Clerk, are authorized to sign the State of Minnesota Joint Powers Agreements.

ADMINISTRATOR

- On motion by Van Hee, second by Groebner, the Board voted unanimously to approve the Southwest Health and Human Services Office Lease Agreement.
- On motion by Forkrud, second by Groebner, the Board voted unanimously to approve the Historical Society Lease Agreement.

- On motion by Groebner, second by Van Hee, the Board voted unanimously to approve the 2022 Snowmobile Grant In-Aid Program Grant Agreement in the amount of \$95,633.00.
- The Board acknowledged receipt and held the first reading of the Redwood-Renville Regional Solid Waste Authority Joint Powers Agreement. The Board will take action in 30 days pursuant to the terms of the agreement at their December 14, 2021 meeting.
- On motion by Van Hee, second by Forkrud, the Board voted unanimously to approve 2021 Tobacco License renewals to the following businesses: Rudra Morgan, LLC, Backroads Bar and Grill, Vesta Bar, Staples (Sanborn Expressway) Farmer’s Coop Association of Milroy, Erickson’s Amoco Handi-Mart and Farmer’s Coop of Belview.

Personnel

- On motion by Van Hee, second by Groebner, the Board voted unanimously to hire Shannon Ness as Full-time County Attorney on the non-union salary schedule at Grade 18, Step 5 at \$40.77 per hour effective December 13, 2021, and authorized 40 hours sick and 40 hours vacation to be placed in her accrual bank, due to experience.
- Discussion held regarding the implementation of President Biden’s COVID mandate for employer’s with 100 employees or more. No action was taken.

COMMISSIONER REPORTS

- The commissioners reported on meetings they attended:

Groebner: Redwood-Renville Regional Solid Waste Authority, Redwood Soil and Water Conservation District

Salfer: Economic Development Authority

Forkrud: Redwood-Renville Regional Solid Waste Authority; Minnesota Public Sector Insurance

Van Hee: Prime West, Redwood County Fair Board; Southwest Regional Development Commission

ADJOURN

- There being no further business, Chair Salfer declared the meeting adjourned at 11:15 a.m.

Jim Salfer, Chair
Board of Commissioners

Attest: _____
Vicki Kletscher
County Administrator

ROAD & BRIDGE AGENDA

November 30, 2021

1. Authorization to pay bills.
2. Authorization to commit \$10,000 in funds to Horseshoe Lake Project.

Other Discussion Items:

*** Redwood County ***



IFX
11/23/21 2:39PM

Audit List for Board COMMISSIONER'S VOUCHERS ENTRIES

Page 2

3 ROAD AND BRIDGE

Vendor No.	Name Account/Formula	Accr	Rpt	Amount	Warrant Description Service Dates	Invoice # Paid On Bhf #	Account/Formula Description On Behalf of Name	1099
1	76720 AUTO VALUE OF REDWOOD FALLS							
	03-330-000-0000-6502			13.89	shop supplies		SHOP MATERIALS & SUPPLIES	N
2	03-330-000-0000-6503			293.18	repair parts		EQUIPMENT REPAIR PARTS & SUPP	N
	76720 AUTO VALUE OF REDWOOD FALLS			307.07		2 Transactions		
4	5071 BANDITS MOWING SERVICE							
	03-330-000-0000-6305			175.00	mowing Lamberton shop		BLDG - REPAIRS & MAINTENANCE	Y
	5071 BANDITS MOWING SERVICE			175.00		1 Transactions		
5	7570 BOLTON & MENK INC							
	03-320-000-0000-6291			55,434.00	consultant engr		PROFESSIONAL & TECHNICAL SER	N
	7570 BOLTON & MENK INC			55,434.00		1 Transactions		
3	8165 BREE/JOAN E							
	03-330-000-0000-6305			720.00	janitorial services		BLDG - REPAIRS & MAINTENANCE	Y
	8165 BREE/JOAN E			720.00		1 Transactions		
8	11941 CHRISTENSEN/BOB							
	03-330-000-0000-6305			50.00	mowing Lucan shop		BLDG - REPAIRS & MAINTENANCE	Y
	11941 CHRISTENSEN/BOB			50.00		1 Transactions		
6	11970 CINTAS CORPORATION							
	03-330-000-0000-6502			140.02	shop supplies		SHOP MATERIALS & SUPPLIES	N
7	03-330-000-0000-6502			140.02	shop supplies		SHOP MATERIALS & SUPPLIES	Y
	11970 CINTAS CORPORATION			280.04		2 Transactions		
9	14080 CRYSTEEL DISTRIBUTING INC							
	03-330-000-0000-6503			26.77	repair parts		EQUIPMENT REPAIR PARTS & SUPP	N
	14080 CRYSTEEL DISTRIBUTING INC			26.77		1 Transactions		
11	20730 ECOWATER SYSTEMS							
	03-301-000-0000-6401			72.00	office supplies		OFFICE SUPPLIES	N
	20730 ECOWATER SYSTEMS			72.00		1 Transactions		
12	21500 ELECTRIC MOTOR CO							
	03-330-000-0000-6502			353.11	shop supplies		SHOP MATERIALS & SUPPLIES	N
13	03-330-000-0000-6503			172.95	repair parts		EQUIPMENT REPAIR PARTS & SUPP	N
	21500 ELECTRIC MOTOR CO			526.06		2 Transactions		
	22551 ERICKSON ENGINEERING LLC							

*** Redwood County ***



IFX 11/23/21 2:39PM

Audit List for Board COMMISSIONER'S VOUCHERS ENTRIES

3 ROAD AND BRIDGE

Vendor No.	Name	Accr	Rpt	Amount	Warrant Description	Service Dates	Invoice #	Account/Formula Description	1099
No.	Account/Formula						Paid On Bhf #	On Behalf of Name	
14	03-320-000-0000-6291			6,302.00	consultant engr			PROFESSIONAL & TECHNICAL SER	N
	22551 ERICKSON ENGINEERING LLC			6,302.00		1 Transactions			
10	03-301-000-0000-6291			150.00	professional services			PROFESSIONAL & TECHNICAL SER	N
	23503 ESTEBO FRANK MUNSHOWER LTD			150.00		1 Transactions			
16	03-330-000-0000-6502			149.29	shop supplies			SHOP MATERIALS & SUPPLIES	N
15	03-330-000-0000-6503			258.57	repair parts			EQUIPMENT REPAIR PARTS & SUPP	N
	24500 FALLS AUTOMOTIVE			407.86		2 Transactions			
17	03-330-000-0000-6504			10,702.57	fuel			FUEL	N
	24589 FARMWARD COOPERATIVE			10,702.57		1 Transactions			
18	03-320-000-0000-6291			1,600.00	professional engr			PROFESSIONAL & TECHNICAL SER	Y
	24700 FIALA/ERNEST G			1,600.00		1 Transactions			
19	03-310-000-0000-6507			169.14	drug testing			MISCELLANEOUS EXPENSES	N
	24725 FIRTSOURCE SOLUTIONS			169.14		1 Transactions			
20	03-330-000-0000-6503			98.30	repair parts			EQUIPMENT REPAIR PARTS & SUPP	N
	26517 FORCE AMERICAN DISTRIBUTING LLC			98.30		1 Transactions			
21	03-310-000-0000-6501			5,333.76	gravel			ROAD MAINTENANCE SUPPLIES & M	N
	31700 GWL FARMS INC			5,333.76		1 Transactions			
22	03-330-000-0000-6306			59.36	repair labor			MAINTENANCE - EQUIPMENT	N
	33715 HERC-U-LIFT			59.36		1 Transactions			
23	03-301-000-0000-6401			426.68	office supplies			OFFICE SUPPLIES	Y
	37640 INNOVATIVE OFFICE SOLUTIONS LLC			426.68		1 Transactions			

*** Redwood County ***



IFX
11/23/21 2:39PM

Audit List for Board COMMISSIONER'S VOUCHERS ENTRIES

3 ROAD AND BRIDGE

Vendor No.	Name Account/Formula	Accr	Rpt	Amount	Warrant Description Service Dates	Invoice # Paid On Bhf #	Account/Formula Description On Behalf of Name	1099
24	41326 JENNIGES/HUDSEN 03-330-000-0000-6305			175.00	mowing Walnut shop		BLDG - REPAIRS & MAINTENANCE	Y
	41326 JENNIGES/HUDSEN			175.00		1 Transactions		
25	43095 JOHN DEERE FINANCIAL 03-330-000-0000-6503			168.52	repair parts		EQUIPMENT REPAIR PARTS & SUPP	N
	43095 JOHN DEERE FINANCIAL			168.52		1 Transactions		
26	46105 KETTNER/ROGER 03-310-000-0000-6501			19,253.57	sand		ROAD MAINTENANCE SUPPLIES & M	Y
	46105 KETTNER/ROGER			19,253.57		1 Transactions		
27	47700 KLABUNDE ELECTRIC INC 03-330-000-0000-6601			5,477.88	salt shed hook up		CAPITAL OUTLAY (\$5,000 AND OVER)	N
	47700 KLABUNDE ELECTRIC INC			5,477.88		1 Transactions		
28	48900 KRIS ENGINEERING INC 03-330-000-0000-6503			12,870.00	cutting edges		EQUIPMENT REPAIR PARTS & SUPP	N
29	48900 KRIS ENGINEERING INC 03-330-000-0000-6503			233.72	repair parts		EQUIPMENT REPAIR PARTS & SUPP	N
	48900 KRIS ENGINEERING INC			13,103.72		2 Transactions		
31	52290 LITTLE FALLS MACHINE 03-330-000-0000-6503			407.77	repair parts		EQUIPMENT REPAIR PARTS & SUPP	N
	52290 LITTLE FALLS MACHINE			407.77		1 Transactions		
32	53100 LOCATORS & SUPPLIES INC 03-310-000-0000-6507			865.35	safety supplies		MISCELLANEOUS EXPENSES	N
	53100 LOCATORS & SUPPLIES INC			865.35		1 Transactions		
30	53227 LOFFLER COMPANIES INC 03-301-000-0000-6310			74.94	copier agreement		OFFICE EQUIPMENT REPAIR & MAINT	Y
	53227 LOFFLER COMPANIES INC			74.94		1 Transactions		
33	54920 M & K BRIDGE CONSTRUCTION INC 03-310-000-0000-6501			5,150.00	bridge repairs		ROAD MAINTENANCE SUPPLIES & M	N
	54920 M & K BRIDGE CONSTRUCTION INC			5,150.00		1 Transactions		
34	55389 MARC 03-330-000-0000-6502			383.86	shop supplies		SHOP MATERIALS & SUPPLIES	N

*** Redwood County ***



IFX 11/23/21 2:39PM

Audit List for Board COMMISSIONER'S VOUCHERS ENTRIES

3 ROAD AND BRIDGE

Vendor No.	Name Account/Formula	Accr	Rpt	Amount	Warrant Description Service Dates	Invoice # Paid On Bhf #	Account/Formula Description On Behalf of Name	1099
55389	MARC			383.86		1 Transactions		
35	56300 MEADOWLAND FARMERS COOP 03-310-000-0000-6501			60.16	maintenance		ROAD MAINTENANCE SUPPLIES & M	N
	56300 MEADOWLAND FARMERS COOP			60.16		1 Transactions		
36	56926 MIELKE OIL COMPANY INC 03-330-000-0000-6503			5,700.00	oil		EQUIPMENT REPAIR PARTS & SUPP	N
	56926 MIELKE OIL COMPANY INC			5,700.00		1 Transactions		
37	57397 MN DEPT OF TRANSPORTATION 03-320-000-0000-6291			4,118.07	professional engr		PROFESSIONAL & TECHNICAL SER	N
	57397 MN DEPT OF TRANSPORTATION			4,118.07		1 Transactions		
38	63540 NORTH CENTRAL INTERNATIONAL INC 03-330-000-0000-6503			2,238.93	repair parts		EQUIPMENT REPAIR PARTS & SUPP	N
	63540 NORTH CENTRAL INTERNATIONAL INC			2,238.93		1 Transactions		
39	63622 NORTHERN SAFETY TECHNOLOGY INC 03-330-000-0000-6503			1,458.70	repair parts		EQUIPMENT REPAIR PARTS & SUPP	N
	63622 NORTHERN SAFETY TECHNOLOGY INC			1,458.70		1 Transactions		
40	63625 NORTHERN STATES SUPPLY INC 03-310-000-0000-6501			87.37	sign supplies		ROAD MAINTENANCE SUPPLIES & M	N
	63625 NORTHERN STATES SUPPLY INC			87.37		1 Transactions		
42	72370 PITNEY BOWES CORP 03-301-000-0000-6401			80.74	office supplies		OFFICE SUPPLIES	N
	72370 PITNEY BOWES CORP			80.74		1 Transactions		
41	71300 PITNEY BOWES GLOBAL 03-301-000-0000-6210			157.17	meter rental		POSTAGE	N
	71300 PITNEY BOWES GLOBAL			157.17		1 Transactions		
43	71900 PLUNKETTS PEST CONTROL INC 03-330-000-0000-6305			1,054.50	shop expenses		BLDG - REPAIRS & MAINTENANCE	N
	71900 PLUNKETTS PEST CONTROL INC			1,054.50		1 Transactions		
44	76169 REDWOOD COUNTY AUD-TREAS 03-310-000-0000-6507			1,807.69	assessments		MISCELLANEOUS EXPENSES	N

*** Redwood County ***



IFX
11/23/21 2:39PM

Audit List for Board COMMISSIONER'S VOUCHERS ENTRIES

3 ROAD AND BRIDGE

Vendor No.	Name Account/Formula	Accr	Rpt	Amount	Warrant Description Service Dates	Invoice # Paid On Bhf #	Account/Formula Description On Behalf of Name	1099
76169	REDWOOD COUNTY AUD-TREAS			1,807.69		1 Transactions		
45	76350 REDWOOD COUNTY RECORDER 03-320-000-0000-6505			46.00	ROW recording		ENG. & CONST.MATERIALS & SUPPI	N
	76350 REDWOOD COUNTY RECORDER			46.00		1 Transactions		
46	76758 REDWOOD TIRE SERVICE INC 03-310-000-0000-6501			20.00	ditch cleanup		ROAD MAINTENANCE SUPPLIES & M	N
	76758 REDWOOD TIRE SERVICE INC			20.00		1 Transactions		
47	78815 RSS GROUP INTERNATIONAL INC 03-330-000-0000-6502			1,334.55	shop supplies		SHOP MATERIALS & SUPPLIES	N
	78815 RSS GROUP INTERNATIONAL INC			1,334.55		1 Transactions		
48	79500 RUNNINGS FARM & FLEET 03-330-000-0000-6502			406.91	shop supplies		SHOP MATERIALS & SUPPLIES	N
49	03-330-000-0000-6503			104.14	repair parts		EQUIPMENT REPAIR PARTS & SUPP	N
	79500 RUNNINGS FARM & FLEET			511.05		2 Transactions		
53	80075 SAFETY-KLEEN SYSTEMS INC 03-330-000-0000-6502			125.44	shop supplies		SHOP MATERIALS & SUPPLIES	N
	80075 SAFETY-KLEEN SYSTEMS INC			125.44		1 Transactions		
54	80180 SCHMIDT CONSTRUCTION INC 03-310-000-0000-6501			15,817.88	sand		ROAD MAINTENANCE SUPPLIES & M	N
	80180 SCHMIDT CONSTRUCTION INC			15,817.88		1 Transactions		
50	80695 SCOTTS LAWN SERVICE and SNOW REMO 03-310-000-0000-6341			1,140.00	mowing Dekalb St		EQUIPMENT RENTAL	N
	80695 SCOTTS LAWN SERVICE and SNOW REMO			1,140.00		1 Transactions		
55	82851 SNOW WHEEL SYSTEMS INC 03-330-000-0000-6503			710.20	repair parts		EQUIPMENT REPAIR PARTS & SUPP	N
	82851 SNOW WHEEL SYSTEMS INC			710.20		1 Transactions		
51	83324 SQUEEGEE BROS 03-330-000-0000-6305			180.00	window washing		BLDG - REPAIRS & MAINTENANCE	N
	83324 SQUEEGEE BROS			180.00		1 Transactions		
	83680 STONEBROOKE ENGINEERING, INC							

*** Redwood County ***



IFX
11/23/21 2:39PM

Audit List for Board COMMISSIONER'S VOUCHERS ENTRIES

3 ROAD AND BRIDGE

Vendor No.	Name Account/Formula	Accr	Rpt	Amount	Warrant Description Service Dates	Invoice # Paid On Bhf #	Account/Formula Description On Behalf of Name	1099
52	83680 STONEBROOKE ENGINEERING, INC			1,719.16	consultant engr	1 Transactions	PROFESSIONAL & TECHNICAL SER	N
	83965 SUMMIT COMPANIES			1,254.50	shop inspections	1 Transactions	SHOP MATERIALS & SUPPLIES	N
56	83965 SUMMIT COMPANIES			1,254.50				
	86020 TBEI INC			533.30	repair parts	1 Transactions	EQUIPMENT REPAIR PARTS & SUPP	N
58	86020 TBEI INC			533.30				
	86350 TERSTEEGS HOLIDAY MARKET			34.31	training exp	1 Transactions	STAFF DEVELOPMENT	N
59	86350 TERSTEEGS HOLIDAY MARKET			34.31				
	88970 TRACY ACE HOME CENTER			149.14	shop supplies	1 Transactions	BLDG - REPAIRS & MAINTENANCE	N
60	88970 TRACY ACE HOME CENTER			149.14				
	88743 TRUCK CENTER COMPANIES			278.84	repair parts	1 Transactions	EQUIPMENT REPAIR PARTS & SUPP	N
57	88743 TRUCK CENTER COMPANIES			278.84				
	89002 TURBES AG SALES & SERVICE LLC			220.00	repair labor	1 Transactions	MAINTENANCE - EQUIPMENT	Y
61	89002 TURBES AG SALES & SERVICE LLC			220.00				
	90428 UNIQUE PAVING MATERIALS			1,350.35	Wanda shop repairs	1 Transactions	ROAD MAINTENANCE SUPPLIES & M	N
62	90428 UNIQUE PAVING MATERIALS			1,350.35				
	90660 VALLEY ASPHALT INC			5,145.53	Wanda shop repairs	1 Transactions	BLDG - REPAIRS & MAINTENANCE	N
63	90660 VALLEY ASPHALT INC			5,145.53				
	92945 WEE'S CLEANING SERVICE LLC			1,955.00	carpet/tile cleaning	1 Transactions	BLDG - REPAIRS & MAINTENANCE	Y
64	92945 WEE'S CLEANING SERVICE LLC			1,955.00				
	93070 WELTSCH EQUIPMENT INC							

*** Redwood County ***



IFX
11/23/21 2:39PM

Audit List for Board COMMISSIONER'S VOUCHERS ENTRIES

3 ROAD AND BRIDGE

Vendor No.	Name Account/Formula	Accr	Rpt	Amount	Warrant Description Service Dates	Invoice # Paid On Bhf #	Account/Formula Description On Behalf of Name	1099
65	03-330-000-0000-6503			582.08	repair parts		EQUIPMENT REPAIR PARTS & SUPP	N
	93070 WELTSCH EQUIPMENT INC			582.08		1 Transactions		
66	03-330-000-0000-6305			360.00	Wanda shop repairs		BLDG - REPAIRS & MAINTENANCE	Y
	99200 Z DOORMEN			360.00		1 Transactions		
67	03-330-000-0000-6503			557.06	repair parts		EQUIPMENT REPAIR PARTS & SUPP	N
	99290 ZIEGLER INC			557.06		1 Transactions		
3 Fund Total:				178,688.94	ROAD AND BRIDGE	61 Vendors	67 Transactions	
Final Total:				178,688.94	61 Vendors	67 Transactions		

*** **Redwood County** ***



Audit List for Board **COMMISSIONER'S VOUCHERS ENTRIES**

Recap by Fund	<u>Fund</u>	<u>AMOUNT</u>	<u>Name</u>
	3	178,688.94	ROAD AND BRIDGE
All Funds		178,688.94	Total

Approved by,

.....

.....

*** Redwood County ***



IFX 11/22/21 9:05AM

REVENUES & EXPENDITURES BUDGET REPORT As of 11/2021

Report Basis: Modified Accrual

Account Number	Status	Quarter To Date	Year To Date	Percent of Year	
				Budget	% of BDG
301 DEPT	ROAD & BRIDGE ADMINISTRATION				
----- REVENUES -----					
03-301-000-0000-5001	PROPERTY TAXES-CURRENT	267,618.88-	1,339,812.92-	1,832,210.00-	73
03-301-000-0000-5015	WHEELAGE TAX	30,902.45-	160,912.44-	180,000.00-	89
03-301-000-0000-5016	LOCAL SALES TAX	197,065.67-	776,033.14-	950,000.00-	82
03-301-000-0000-5020	SEVERED MINERAL TAXES	0.00	6.72-	0.00	0
03-301-000-0000-5205	DISPARITY REDUCTION AID	0.00	3,152.35-	6,435.00-	49
03-301-000-0000-5208	MARKET VALUE CREDIT	27,799.00-	27,799.00-	57,030.00-	49
03-301-000-0000-5230	TOWN BRIDGE REVENUE	238,546.43-	1,073,691.48-	560,000.00-	192
03-301-000-0000-5235	TOWN ROAD REVENUE	0.00	595,608.00-	548,673.00-	109
03-301-000-0000-5240	ST. OF MN. - REG. MAINT.	0.00	2,106,563.40-	1,928,427.00-	109
03-301-000-0000-5242	ST. OF MN. - MUN.MAINT.	0.00	131,590.95-	180,000.00-	73
03-301-000-0000-5244	ST. OF MN. - REG.CONST.	140,940.58-	3,607,613.10-	3,554,000.00-	102
03-301-000-0000-5246	ST. OF MN - MUN. CONST.	0.00	436,747.57-	352,000.00-	124
03-301-000-0000-5249	INTERGOVERNMENTAL REIMBURSEMENTS-LC	1,502.50-	36,475.50-	837,834.00-	4
03-301-000-0000-5333	BRIDGE BONDING REVENUE	0.00	810,151.78-	400,000.00-	203
03-301-000-0000-5455	FEDERAL FUNDS - HIGHWAY	0.00	11,165.93-	0.00	0
03-301-000-0000-5502	FEES & SERVICES	11,170.00-	13,690.95-	6,000.00-	228
03-301-000-0000-5503	OVERWEIGHT TRUCK PERMITS	0.00	19,300.00-	0.00	0
03-301-000-0000-5710	INTEREST INCOME	0.00	0.00	40,000.00-	0
03-301-000-0000-5751	CONTRIBUTIONS AND DONATIONS	0.00	1,000.00-	0.00	0
03-301-000-0000-5810	LAND LEASE & RENTAL	0.00	50.00-	50.00-	100
03-301-000-0000-5850	SALES OF MATERIALS	12,077.83-	86,260.72-	50,000.00-	173
03-301-000-0000-5920	SALE OF CAPITAL ASSET	0.00	50,490.00-	51,000.00-	99
----- EXPENDITURES -----					
03-301-000-0000-6103	SALARIES & WAGES-REGULAR	45,315.21	245,466.79	299,190.00	82
03-301-000-0000-6105	SALARIES & WAGES-PART TIME	4,346.25	35,055.00	0.00	0
03-301-000-0000-6113	MEAL EXPENSE-TAXABLE	21.07	21.07	200.00	11
03-301-000-0000-6153	EMPLOYER CAFETERIA CONTRIBUTION	4,472.04	30,081.72	40,549.00	74
03-301-000-0000-6163	PERA-COUNTY SHARE	3,398.64	18,223.76	22,439.00	81
03-301-000-0000-6172	WORKERS' COMPENSATION	0.00	34,548.00	40,079.00	86
03-301-000-0000-6175	FICA-COUNTY SHARE	2,982.08	16,848.20	18,550.00	91
03-301-000-0000-6176	MEDICARE-COUNTY SHARE	697.41	3,940.31	4,338.00	91
03-301-000-0000-6202	TELEPHONE/FAX EXPENSE	2,848.30	18,844.84	22,000.00	86
03-301-000-0000-6210	POSTAGE	0.00	1,596.51	3,000.00	53
03-301-000-0000-6230	PRINTING & PUBLISHING	0.00	1,190.74	700.00	170

*** Redwood County ***



IFX 11/22/21 9:05AM

REVENUES & EXPENDITURES BUDGET REPORT As of 11/2021

Report Basis: Modified Accrual

Account Number	Status	Quarter To Date	Year To Date	Percent of Year		
				Budget	% of BDG	
03-301-000-0000-6241	SUBSCRIPTIONS	102.00	140.85	200.00	70	
03-301-000-0000-6242	DUES	0.00	3,172.00	4,000.00	79	
03-301-000-0000-6262	STATE AUDIT	940.50	940.50	1,700.00	55	
03-301-000-0000-6291	PROFESSIONAL & TECHNICAL SERVICES	625.00	11,117.08	29,000.00	38	
03-301-000-0000-6310	OFFICE EQUIPMENT REPAIR & MAINT.	198.05	1,519.36	4,000.00	38	
03-301-000-0000-6331	MILEAGE	0.00	3,000.56	4,200.00	71	
03-301-000-0000-6332	STAFF DEVELOPMENT	1,789.64	4,272.07	3,000.00	142	
03-301-000-0000-6334	LODGING & EXPENSE	84.10	184.10	1,000.00	18	
03-301-000-0000-6351	INSURANCE-PROPERTY & LIABILITY	86.00-	69,462.00	78,000.00	89	
03-301-000-0000-6401	OFFICE SUPPLIES	1,140.91	4,320.69	6,000.00	72	
03-301-000-0000-6507	MISCELLANEOUS EXPENSES	71.60	71.60	1,200.00	6	
03-301-000-0000-6601	CAPITAL OUTLAY (\$5,000 AND OVER)	0.00	9,262.82	40,000.00	23	
03-301-000-0000-6891	EXP REIMBURSEMENTS - EXTERNAL	1,286.71-	7,623.08-	13,000.00-	59	
03-301-000-0000-6910	TRANSFERS IN	0.00	199,005.00-	0.00	0	
301 DEPT	Totals ROAD & BRIDGE ADMINISTRATION		927,623.34-	11,288,115.95-	11,533,659.00-	98
			67,660.09	306,652.49	610,345.00	50
			859,963.25-	10,981,463.46-	10,923,314.00-	101
310 DEPT	HIGHWAY MAINTENANCE					
----- REVENUES -----						
03-310-000-0000-5249	INTERGOVERNMENTAL REIMBURSEMENTS-LC	0.00	5,467.16-	4,000.00-	137	
03-310-000-0000-5301	STATE GRANTS	0.00	20,236.92-	0.00	0	
03-310-000-0000-5401	DISASTER GRANTS	0.00	64,824.66-	0.00	0	
03-310-000-0000-5455	FEDERAL FUNDS - HIGHWAY	0.00	213,462.00-	0.00	0	
03-310-000-0000-5901	EXP REIMBURSEMENTS - EXTERNAL	0.00	39.98-	0.00	0	
----- EXPENDITURES -----						
03-310-000-0000-6103	SALARIES & WAGES-REGULAR	141,772.83	765,020.77	951,502.00	80	
03-310-000-0000-6105	SALARIES & WAGES-PART TIME	0.00	41,377.20	11,000.00	376	
03-310-000-0000-6107	SALARIES & WAGES-OVERTIME	1,179.48	20,803.67	4,351.00	478	
03-310-000-0000-6113	MEAL EXPENSE-TAXABLE	0.00	92.01	200.00	46	
03-310-000-0000-6153	EMPLOYER CAFETERIA CONTRIBUTION	24,397.11	170,338.07	193,758.00	88	
03-310-000-0000-6163	PERA-COUNTY SHARE	10,721.42	58,880.16	71,689.00	82	
03-310-000-0000-6175	FICA-COUNTY SHARE	8,488.45	48,742.25	59,945.00	81	
03-310-000-0000-6176	MEDICARE-COUNTY SHARE	1,985.19	11,399.41	14,019.00	81	
03-310-000-0000-6202	TELEPHONE/FAX EXPENSE	60.00	330.00	200.00	165	
03-310-000-0000-6292	CONTRACT PAYMENTS	27,453.81	27,453.81	100,000.00	27	
03-310-000-0000-6341	EQUIPMENT RENTAL	10,702.25	34,923.02	75,000.00	47	
03-310-000-0000-6501	ROAD MAINTENANCE SUPPLIES & MATERIALS	113,246.75	795,186.55	600,000.00	133	

*** Redwood County ***



REVENUES & EXPENDITURES BUDGET REPORT As of 11/2021

Report Basis: Modified Accrual

3 FUND ROAD AND BRIDGE		Status	Quarter To Date	Year To Date	Percent of Year Budget	92% % of BDG
<u>Account Number</u>						
03-310-000-0000-6506	MINOR EQUIP. PURCHASES		0.00	0.00	500.00	0
03-310-000-0000-6507	MISCELLANEOUS EXPENSES		11,438.24	17,693.40	13,000.00	136
03-310-000-0000-6508	TOWN ROAD DISTRIBUTION		0.00	595,608.00	548,673.00	109
03-310-000-0000-6601	CAPITAL OUTLAY (\$5,000 AND OVER)		1,021.50	138,355.43	955,000.00	14
310 DEPT	Totals HIGHWAY MAINTENANCE	Revenue	0.00	304,030.72-	4,000.00-	7601
		Expend.	352,467.03	2,726,203.75	3,598,837.00	76
		Net	352,467.03	2,422,173.03	3,594,837.00	67
320 DEPT	HIGHWAY CONSTRUCTION & ENGINEERING					
----- EXPENDITURES -----						
03-320-000-0000-6103	SALARIES & WAGES-REGULAR		21,302.41	116,036.50	138,998.00	83
03-320-000-0000-6105	SALARIES & WAGES-PART TIME		0.00	14,571.63	2,175.00	670
03-320-000-0000-6107	SALARIES & WAGES-OVERTIME		480.33	22,185.72	11,000.00	202
03-320-000-0000-6153	EMPLOYER CAFETERIA CONTRIBUTION		3,913.50	26,832.50	26,284.00	102
03-320-000-0000-6163	PERA-COUNTY SHARE		1,633.70	10,020.04	10,588.00	95
03-320-000-0000-6175	FICA-COUNTY SHARE		1,219.53	8,547.69	9,435.00	91
03-320-000-0000-6176	MEDICARE-COUNTY SHARE		285.21	1,999.05	2,207.00	91
03-320-000-0000-6230	PRINTING & PUBLISHING		0.00	0.00	500.00	0
03-320-000-0000-6291	PROFESSIONAL & TECHNICAL SERVICES		188,488.61	611,951.07	175,000.00	350
03-320-000-0000-6292	CONTRACT PAYMENTS		1,041,382.69	7,584,137.47	7,680,000.00	99
03-320-000-0000-6366	RIGHT OF WAY - PERMANENT EASEMENTS		29,206.00	29,206.00	145,000.00	20
03-320-000-0000-6367	RIGHT OF WAY-TEMP.EASE.& OTHER		0.00	0.00	2,500.00	0
03-320-000-0000-6505	ENG. & CONST.MATERIALS & SUPPLIESS		667.29	14,049.70	10,000.00	140
03-320-000-0000-6507	MISCELLANEOUS EXPENSES		720.00	26,350.06	500.00	5270
----- REVENUES -----						
03-320-000-2720-5940	2021A GENERAL OBLIGATION BONDS ISSUED		6,985,589.75-	6,985,589.75-	0.00	0
----- EXPENDITURES -----						
03-320-000-2720-6701	ADMINISTRATIVE FEES 2021A BONDS		35,262.04	35,262.04	0.00	0
320 DEPT	Totals HIGHWAY CONSTRUCTION & ENGINEERING	Revenue	6,985,589.75-	6,985,589.75-	0.00	0
		Expend.	1,324,561.31	8,501,149.47	8,214,187.00	103
		Net	5,661,028.44-	1,515,559.72	8,214,187.00	18
330 DEPT	EQUIPMENT MAINTENANCE & SHOP					
----- REVENUES -----						
03-330-000-0000-5980	INSURANCE RECOVERIES		0.00	6,540.53-	0.00	0
----- EXPENDITURES -----						
03-330-000-0000-6103	SALARIES & WAGES-REGULAR		10,774.40	58,181.76	70,303.00	83
03-330-000-0000-6105	SALARIES & WAGES-PART TIME		3,445.20	12,026.88	0.00	0
03-330-000-0000-6107	SALARIES & WAGES-OVERTIME		1,252.80	2,793.21	725.00	385

*** Redwood County ***



REVENUES & EXPENDITURES BUDGET REPORT As of 11/2021

Report Basis: Modified Accrual

3 FUND ROAD AND BRIDGE		Status	Quarter To Date	Year To Date	Percent of Year Budget	92% % of BDG
<u>Account Number</u>						
03-330-000-0000-6153	EMPLOYER CAFETERIA CONTRIBUTION		1,118.01	7,826.07	8,944.00	88
03-330-000-0000-6163	PERA-COUNTY SHARE		808.08	4,479.16	5,327.00	84
03-330-000-0000-6175	FICA-COUNTY SHARE		945.04	4,431.14	4,404.00	101
03-330-000-0000-6176	MEDICARE-COUNTY SHARE		221.01	1,036.30	1,030.00	101
03-330-000-0000-6251	UTILITIES		17,587.31	56,261.74	70,000.00	80
03-330-000-0000-6305	BLDG - REPAIRS & MAINTENANCE		6,431.37	84,849.67	40,000.00	212
03-330-000-0000-6306	MAINTENANCE - EQUIPMENT		7,668.88	57,941.52	30,000.00	193
03-330-000-0000-6342	BUILDING RENT		0.00	175.00	1,050.00	17
03-330-000-0000-6502	SHOP MATERIALS & SUPPLIES		4,462.45	28,436.43	55,000.00	52
03-330-000-0000-6503	EQUIPMENT REPAIR PARTS & SUPPLIES		38,403.24	210,658.04	175,000.00	120
03-330-000-0000-6504	FUEL		41,499.37	254,663.09	225,000.00	113
03-330-000-0000-6506	MINOR EQUIP. PURCHASES		1,100.00	1,100.00	25,000.00	4
03-330-000-0000-6507	MISCELLANEOUS EXPENSES		0.00	228.00	15,000.00	2
03-330-000-0000-6601	CAPITAL OUTLAY (\$5,000 AND OVER)		19,769.94	246,218.16	279,000.00	88
03-330-000-0000-6910	TRANSFERS IN		0.00	11,270.43-	0.00	0
330 DEPT	Totals EQUIPMENT MAINTENANCE & SHOP	Revenue	0.00	6,540.53-	0.00	0
		Expend.	155,487.10	1,020,035.74	1,005,783.00	101
		Net	155,487.10	1,013,495.21	1,005,783.00	101
340 DEPT	ROAD & BRIDGE OTHER COSTS					
----- EXPENDITURES -----						
03-340-000-0000-6507	MISCELLANEOUS EXPENSES		103.95	103.95	0.00	0
340 DEPT	Totals ROAD & BRIDGE OTHER COSTS	Revenue				
		Expend.	103.95	103.95	0.00	0
		Net	103.95	103.95	0.00	0
3 FUND	Totals ROAD AND BRIDGE	Revenue	7,913,213.09-	18,584,276.95-	11,537,659.00-	161
		Expend.	1,900,279.48	12,554,145.40	13,429,152.00	93
		Net	6,012,933.61-	6,030,131.55-	1,891,493.00	319-
FINAL TOTALS	104 Accounts	Revenue	7,913,213.09-	18,584,276.95-	11,537,659.00-	161
		Expend.	1,900,279.48	12,554,145.40	13,429,152.00	93
		Net	6,012,933.61-	6,030,131.55-	1,891,493.00	319-

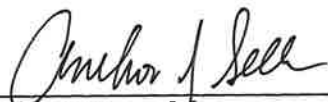

 Anthony Sellner, Co. Engr. Date



REQUEST FOR BOARD ACTION

Requested Board Date:		Originating Dept.:	
Preferred 2nd Date:			
Discussion Item:		Presenter:	
		estimated time needed:	
Board Action:	<input type="checkbox"/> Yes, action required	<input type="checkbox"/> No, informational only	

If Action, Board Motion Requested:

Background Information:

Supporting Documents: Attached None

County Attorney Reviewed Information: Completed In Progress Not applicable

Administrators Comments:

Reviewed by Administrator: Yes No

**** The deadline for submitting items is 4:30 p.m. Wednesday prior to a Tuesday board day ****



OUTLET
STRUCTURE

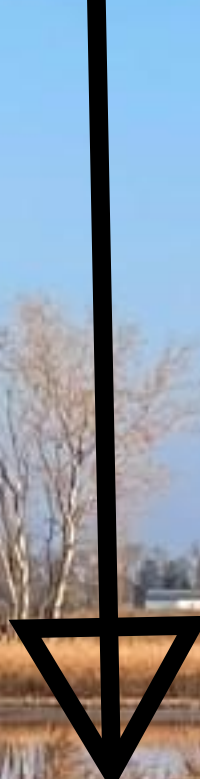

**OUTLET
STRUCTURE**



2018 Flooding

←
To Milroy

CSAH 8

28

Westline

29

Distance: 53 Feet

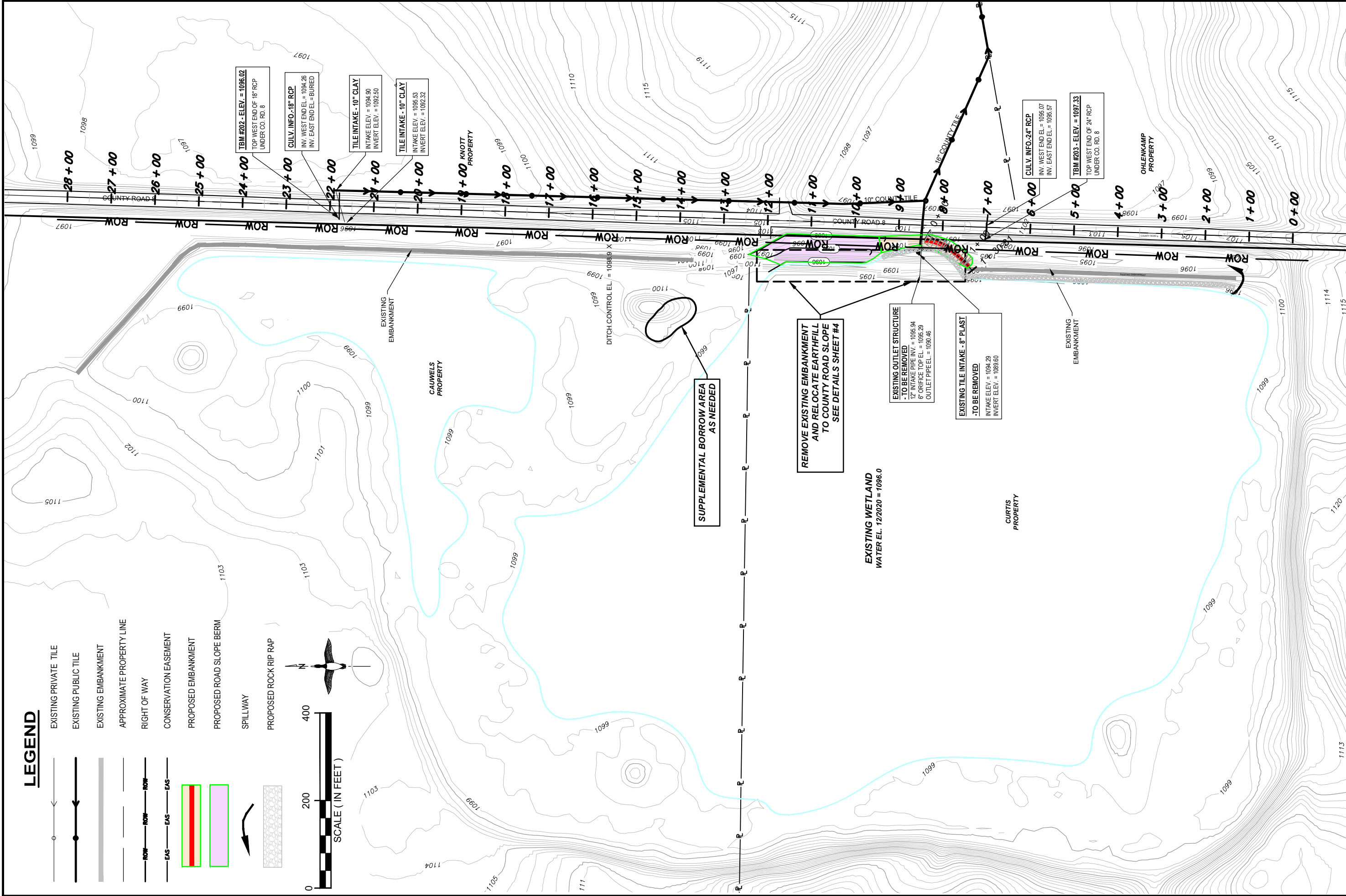

LEGEND

- EXISTING PRIVATE TILE
- EXISTING PUBLIC TILE
- EXISTING EMBANKMENT
- APPROXIMATE PROPERTY LINE
- RIGHT OF WAY
- CONSERVATION EASEMENT
- PROPOSED EMBANKMENT
- PROPOSED ROAD SLOPE BERM
- SPILLWAY
- PROPOSED ROCK RIP RAP

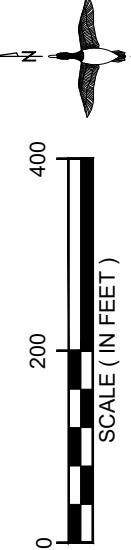

PROJECT #:
02409 REPAIR

SHEET NO.
2 OF 9

DATE: 9/30/2021

LIC. NO. 41163

TERRY RAGAN

PLANVIEW

HORSESHOE LAKE REPAIR - REDWOOD COUNTY

REPAIR WETLAND RESTORATION

I HEREBY CERTIFY THAT THIS PLAN, SPECIFICATION, OR REPORT WAS PREPARED BY ME OR UNDER MY DIRECT SUPERVISION AND THAT I AM A DULY LICENSED PROFESSIONAL ENGINEER UNDER THE LAWS OF THE STATE OF MINNESOTA.

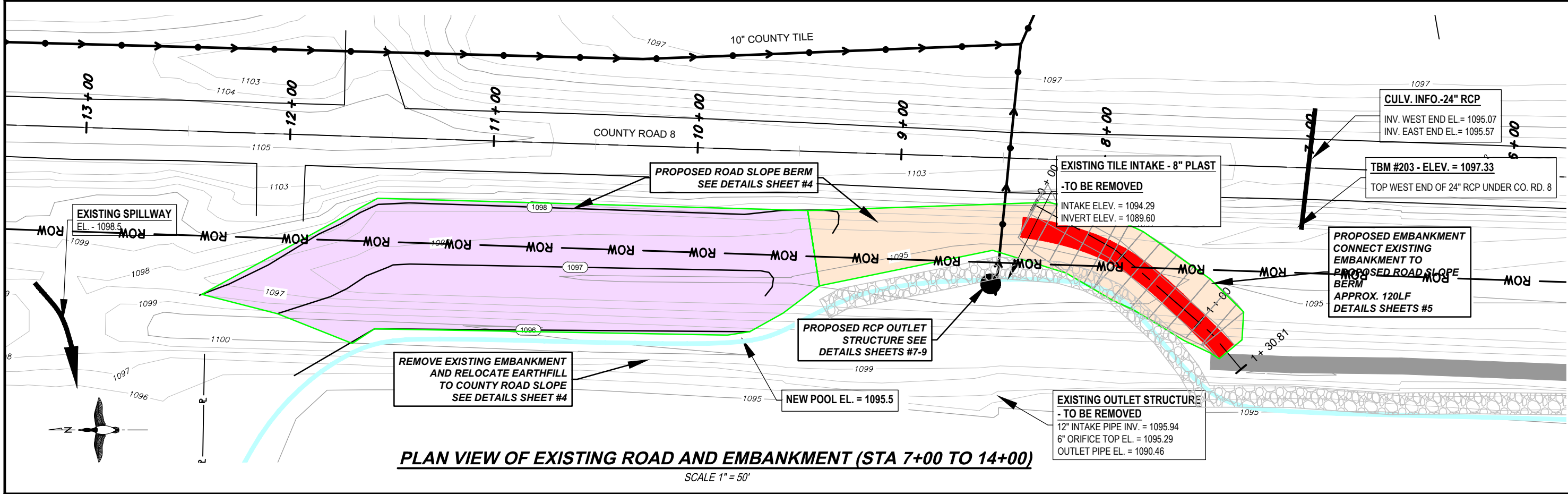
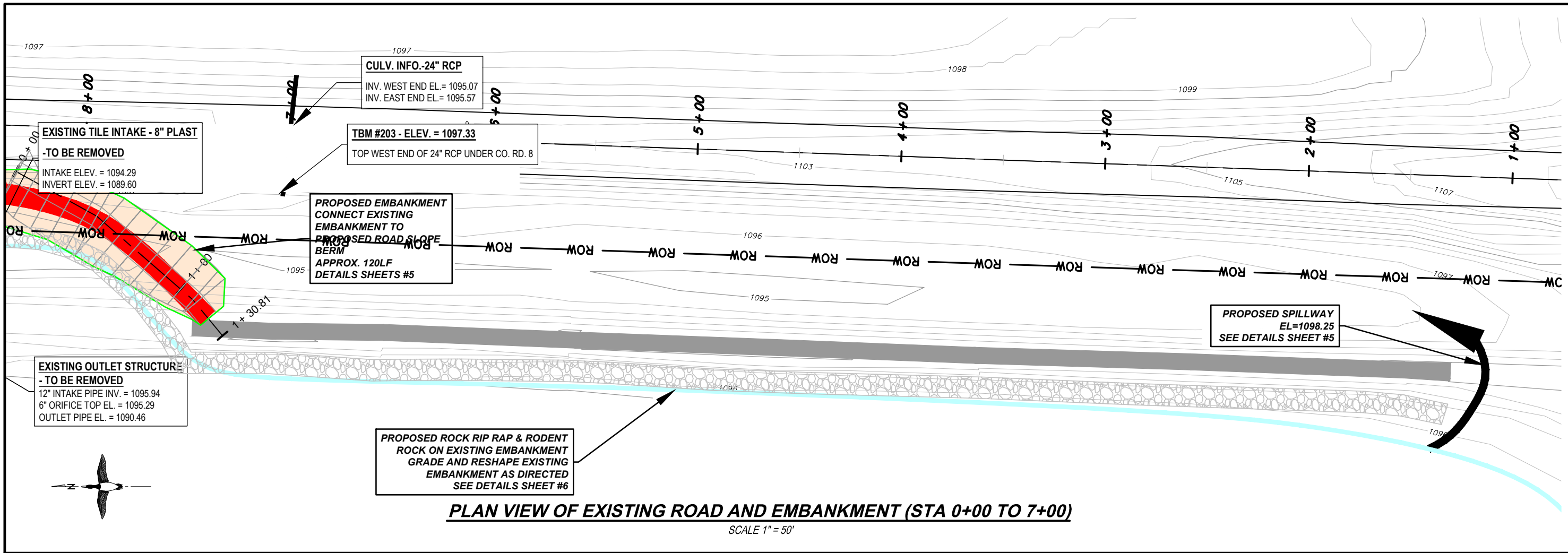

I HEREBY CERTIFY THAT THIS PLAN, SPECIFICATION, OR REPORT WAS PREPARED BY ME OR UNDER MY DIRECT SUPERVISION AND THAT I AM A DULY LICENSED PROFESSIONAL ENGINEER UNDER THE LAWS OF THE STATE OF MINNESOTA.

Terry Ragan
TERRY RAGAN
DATE: 9/30/2021
LIC. NO. 41163



HORSESHOE LAKE REPAIR - REDWOOD COUNTY
REPAIR WETLAND RESTORATION
ZOOM PLANVIEW

PROJECT #:
02409 REPAIR

SHEET NO.
3 OF 9

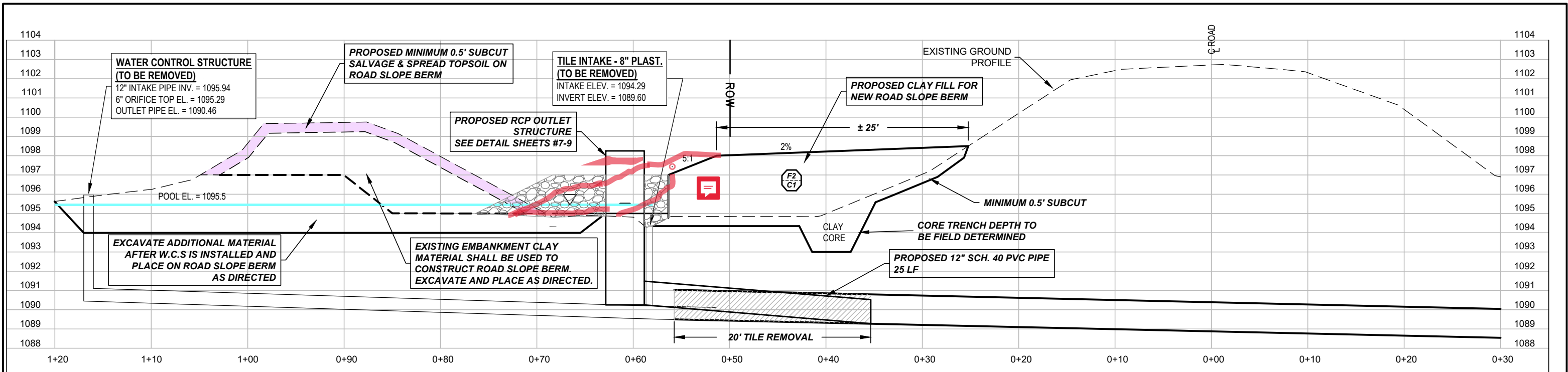

X-SECTION AT STA 8+50

SCALE 1" = 10'

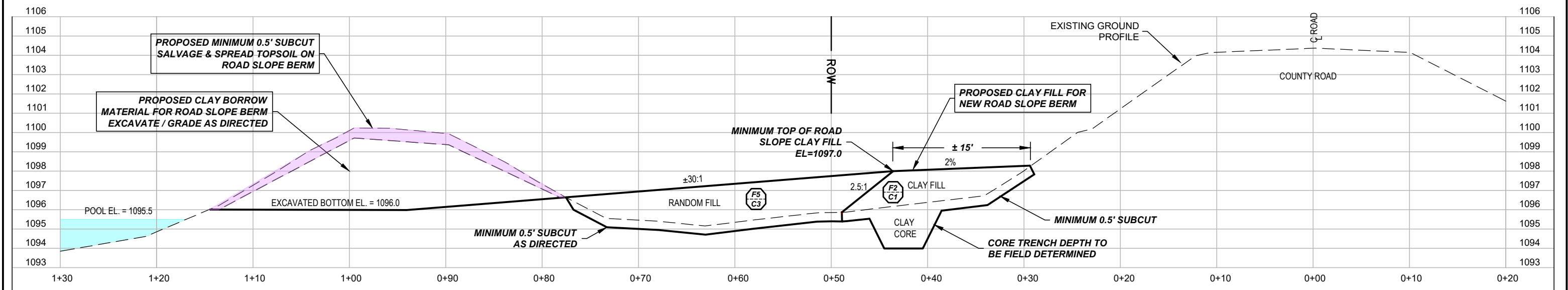

X-SECTION AT STA 11+00

SCALE 1" = 10'

4 of 9	02409 REPAIR PROJECT #	HORSESHOE LAKE REPAIR - REDWOOD COUNTY REPAIR WETLAND RESTORATION
	SHEET NO.	ROAD SLOPE BERM

	I HEREBY CERTIFY THAT THIS PLAN, SPECIFICATION, OR REPORT WAS PREPARED BY ME OR UNDER MY DIRECT SUPERVISION AND THAT I AM A DULY LICENSED PROFESSIONAL ENGINEER UNDER THE LAWS OF THE STATE OF MINNESOTA.
	DATE: 9/30/2021 LIC. NO. 41163

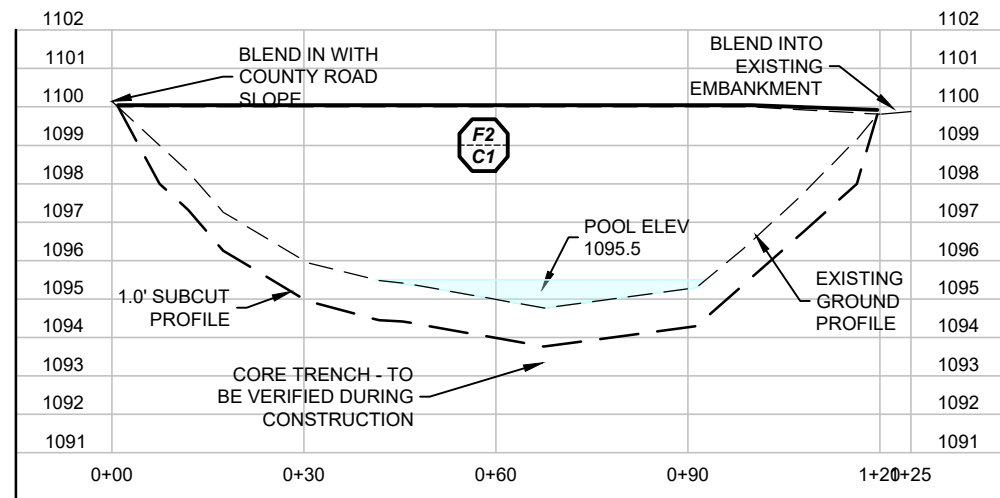

PROPOSED EMBANKMENT
SCALE 1" = 30'

EMBANKMENT DESIGN	
TOP WIDTH	= 10 FT
FRONT SLOPE	= 3:1 (H:V)
BACK SLOPE	= 3:1 (H:V)
SETTLEMENT	= 10%
SUBCUT QTY	= 150 CY
FILL QTY	= 450 CY

F#	FILL TYPE ID
C#	COMPACTION CLASS
F# C#	DENOTES REQUIRED TYPE OF FILL AND COMPACTION METHOD. SEE BWSR SPEC 2.230

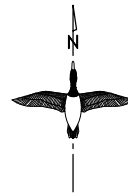

PROPOSED EMBANKMENT
CONNECT EXISTING
EMBANKMENT TO
PROPOSED ROAD SLOPE
BERM
APPROX. 120LF
DETAILS THIS SHEET

LEGEND

- EXISTING PRIVATE TILE
- EXISTING PUBLIC TILE
- EXISTING EMBANKMENT
- APPROXIMATE PROPERTY LINE
- RIGHT OF WAY
- CONSERVATION EASEMENT
- PROPOSED EMBANKMENT
- PROPOSED ROAD SLOPE BERM

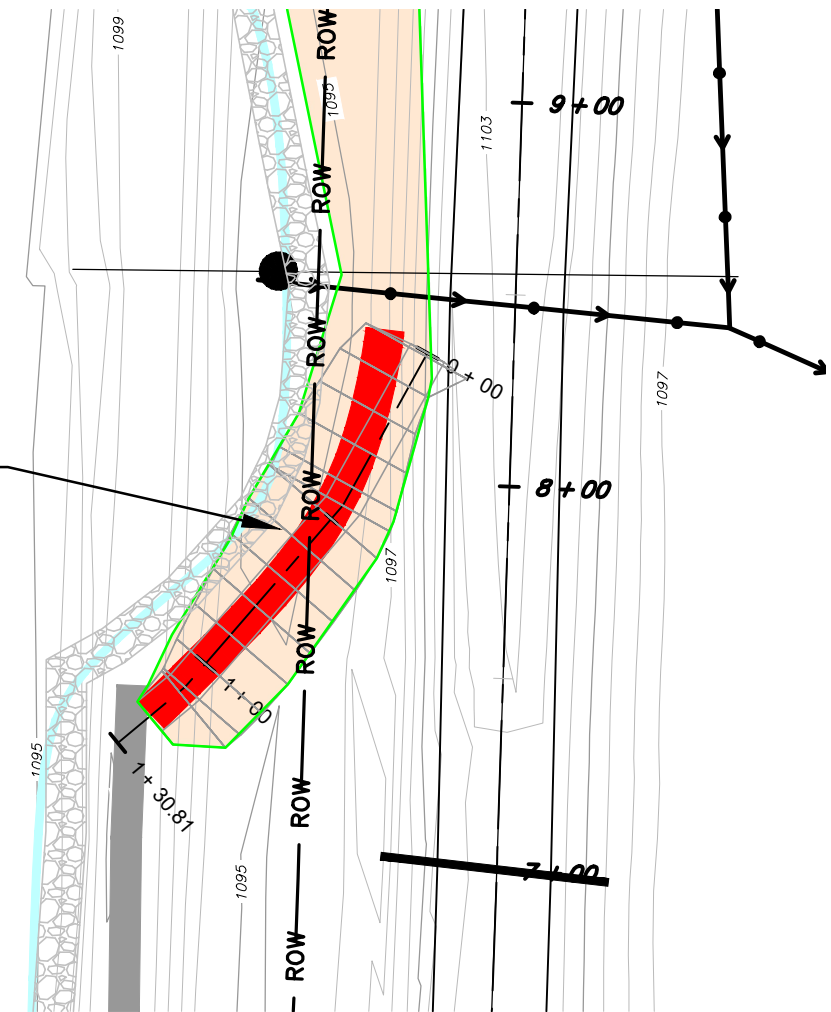

EMBANKMENT CONSTRUCTION REQUIREMENTS

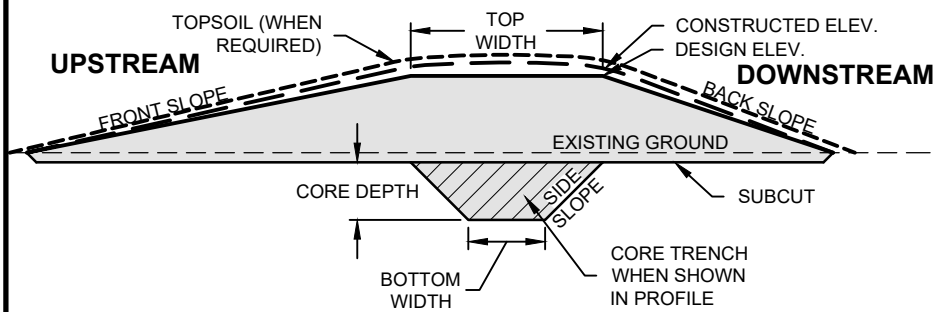

EMBANKMENT DETAIL
NOT TO SCALE

SUBCUT DIMENSIONS SHOWN ON EMBANKMENT PROFILE ARE MINIMUMS. THE SUBCUT DEPTH MAY NEED TO BE INCREASED BASED ON SITE AND SOIL CONDITIONS. ENGINEER MAY DIRECT WHEN TO EXCAVATE TO DIFFERENT DEPTHS THAN SHOWN.

THE FILL VOLUME SHOWN FOR AN EMBANKMENT INCLUDES QUANTITIES FOR SUBCUT AND SETTLEMENT ALLOWANCE.

PLACE ±4 INCHES OF STRIPPED TOPSOIL ON THE ENTIRE EMBANKMENT SURFACE AFTER CONSTRUCTED ELEVATION IS ACHIEVED. TOPSOIL MATERIAL USED SHALL BE SUITABLE FOR VEGETATION ESTABLISHMENT.

WHEN REQUIRED ON EMBANKMENT PROFILE, CORE TRENCH DEPTHS MAY VARY BASED ON SITE AND SOIL CONDITIONS. ENGINEER MAY DIRECT WHEN TO EXCAVATE TO DIFFERENT DEPTHS THAN SHOWN.

DETERMINING CONSTRUCTED ELEVATION

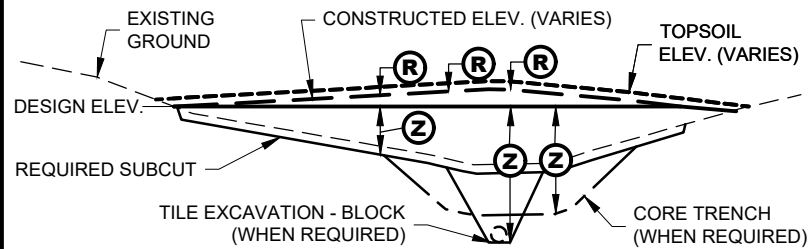

CONSTRUCTED ELEVATION INCLUDES REQUIRED AMOUNT OF OVERBUILD ADDED TO DESIGN ELEVATION TO ACCOUNT FOR EXPECTED SETTLEMENT.

- Z** - TOTAL FILL HEIGHT (DESIGN ELEVATION - SUBGRADE ELEVATION)
- R** - SETTLEMENT AMOUNT (OVERBUILD) = **Z** x SETTLEMENT % (PER PLAN)

NOTE: THE FIGURE PROVIDED ILLUSTRATES THIS FOR A CONSTRUCTED EMBANKMENT, HOWEVER, THIS REQUIREMENT FOR OVERBUILD APPLIES TO ALL CONSTRUCTED FILLS. TOPSOIL NOT TO BE INCLUDED IN CONSTRUCTED ELEVATION.

SPILLWAY CONSTRUCTION REQUIREMENTS

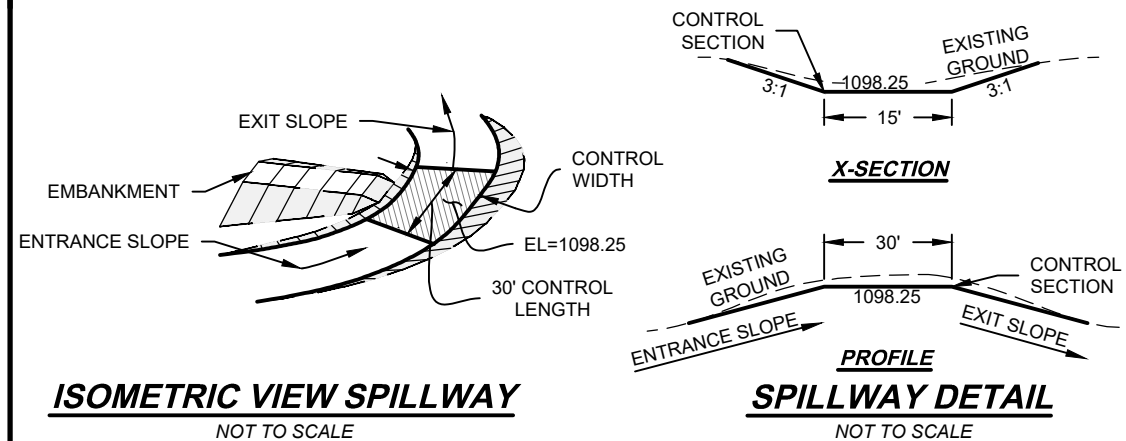

ISOMETRIC VIEW SPILLWAY
NOT TO SCALE

ENTRANCE AND EXIT SLOPES SHALL BE EXCAVATED / GRADED TO ENSURE POSITIVE DRAINAGE IN AND OUT OF SPILLWAY CONTROL SECTION.

ELEVATION AND WIDTH OF CONTROL SECTION SHALL BE AS SHOWN ON PLAN VIEW AND/OR ASSOCIATED EMBANKMENT PROFILE

THE ABILITY TO ESTABLISH QUALITY VEGETATION WITHIN THE CONSTRUCTED SPILLWAY SECTION WILL BE CRITICAL TO THE SPILLWAY'S FUNCTION. WHEN SPILLWAY EXCAVATION RESULTS IN A CONDITION THAT IS UNSUITABLE FOR VEGETATION ESTABLISHMENT, OVER EXCAVATE AS DIRECTED OR NECESSARY TO PROVIDE SUITABLE SUBSTRATE FOR VEGETATION ESTABLISHMENT. (TYPICALLY 4"-6" TOPSOIL)

FINISHED SURFACE SHALL BE REASONABLY SMOOTH AND ACHIEVE / MEET CONTROL ELEVATION SHOWN ABOVE PRIOR TO SEEDING.

I HEREBY CERTIFY THAT THIS PLAN, SPECIFICATION, OR REPORT WAS PREPARED BY ME OR UNDER MY DIRECT SUPERVISION AND THAT I AM A DULY LICENSED PROFESSIONAL ENGINEER UNDER THE LAWS OF THE STATE OF MINNESOTA.

TERRY RAGAN
DATE: 9/30/2021
LIC. NO. 41163



HORSESHOE LAKE REPAIR - REDWOOD COUNTY
REPAIR WETLAND RESTORATION
PROPOSED EMBANKMENT

PROJECT #:
02409 REPAIR

SHEET NO.
5 OF **9**

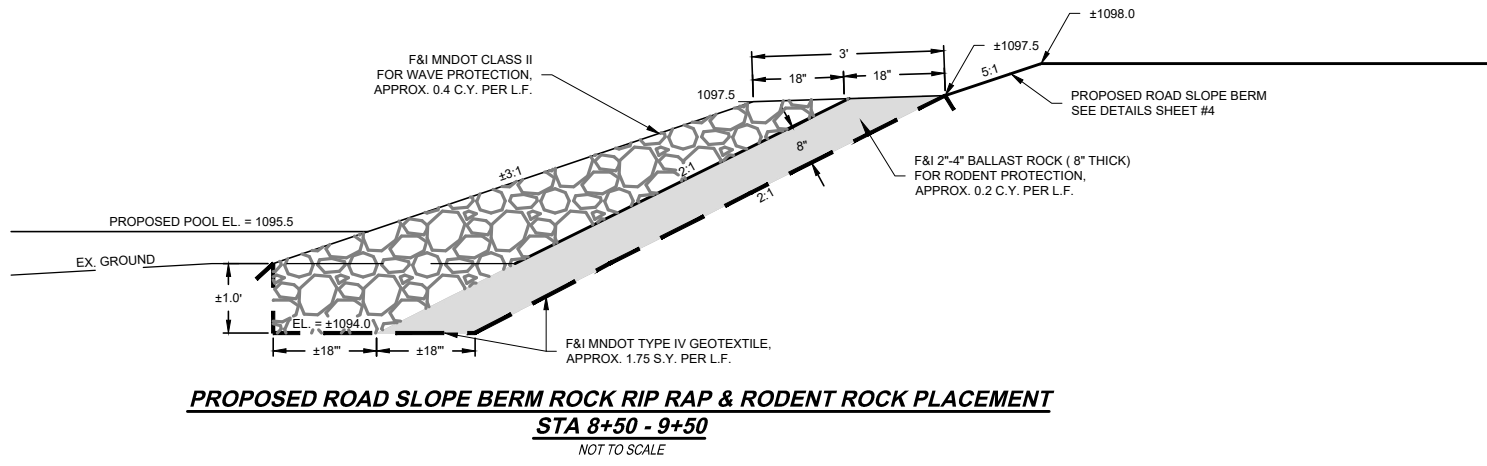

PROPOSED ROAD SLOPE BERM ROCK RIP RAP & RODENT ROCK PLACEMENT
STA 8+50 - 9+50
 NOT TO SCALE

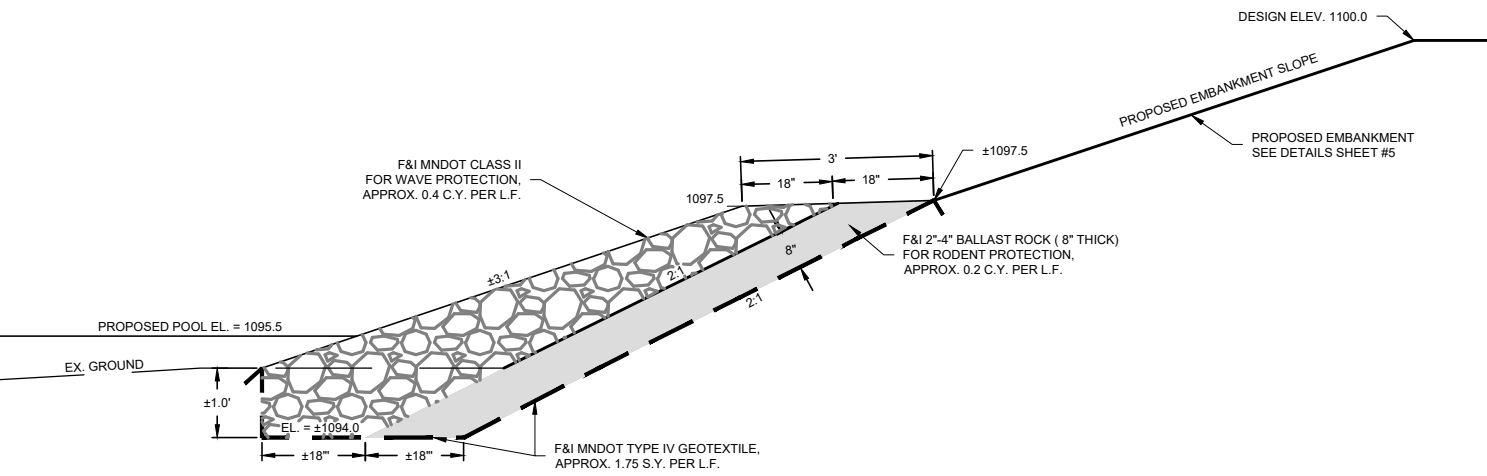

PROPOSED EMBANKMENT ROCK RIP RAP & RODENT ROCK PLACEMENT
STA 7+50 - 8+50
 NOT TO SCALE

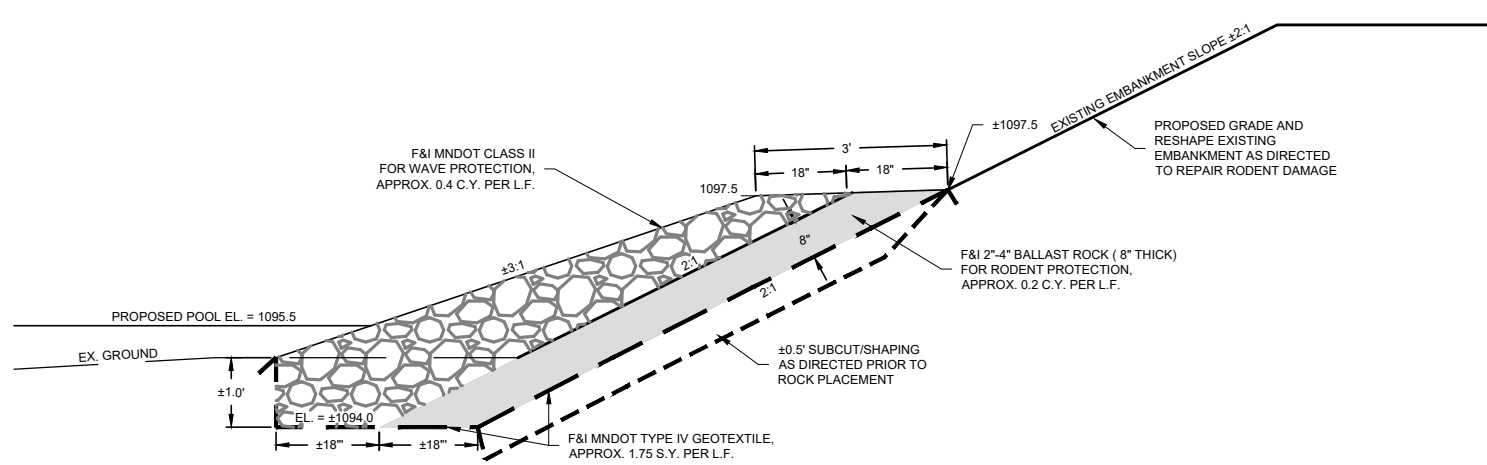

EXISTING EMBANKMENT ROCK RIP RAP & RODENT ROCK PLACEMENT
STA 1+20 - 9+50
 NOT TO SCALE

LEGEND

- EXISTING PRIVATE TILE
- EXISTING PUBLIC TILE
- EXISTING EMBANKMENT
- APPROXIMATE PROPERTY LINE
- RIGHT OF WAY
- CONSERVATION EASEMENT
- PROPOSED EMBANKMENT
- PROPOSED ROAD SLOPE BERM
- SPILLWAY
- PROPOSED ROCK RIP RAP

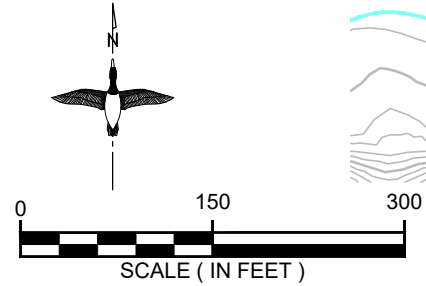

ROCK NOTE: HAUL TICKET ARE REQUIRED. CONTRACTOR SHALL PROVIDE WEIGHT TICKETS FOR ROCK RIP RAP & 2-4" ROCK. CONVERSION FOR ROCK RIP RAP AND 2-4" ROCK IS 1.5 TONS PER CUBIC YARD.

ROAD SLOPE BERM ROCK LOCATION STA 8+50 - 9+50

PROPOSED EMBANKMENT ROCK LOCATION APPROX. STA 7+50 - 8+50

EXISTING EMBANKMENT ROCK LOCATION APPROX. STA 1+20 - 7+50

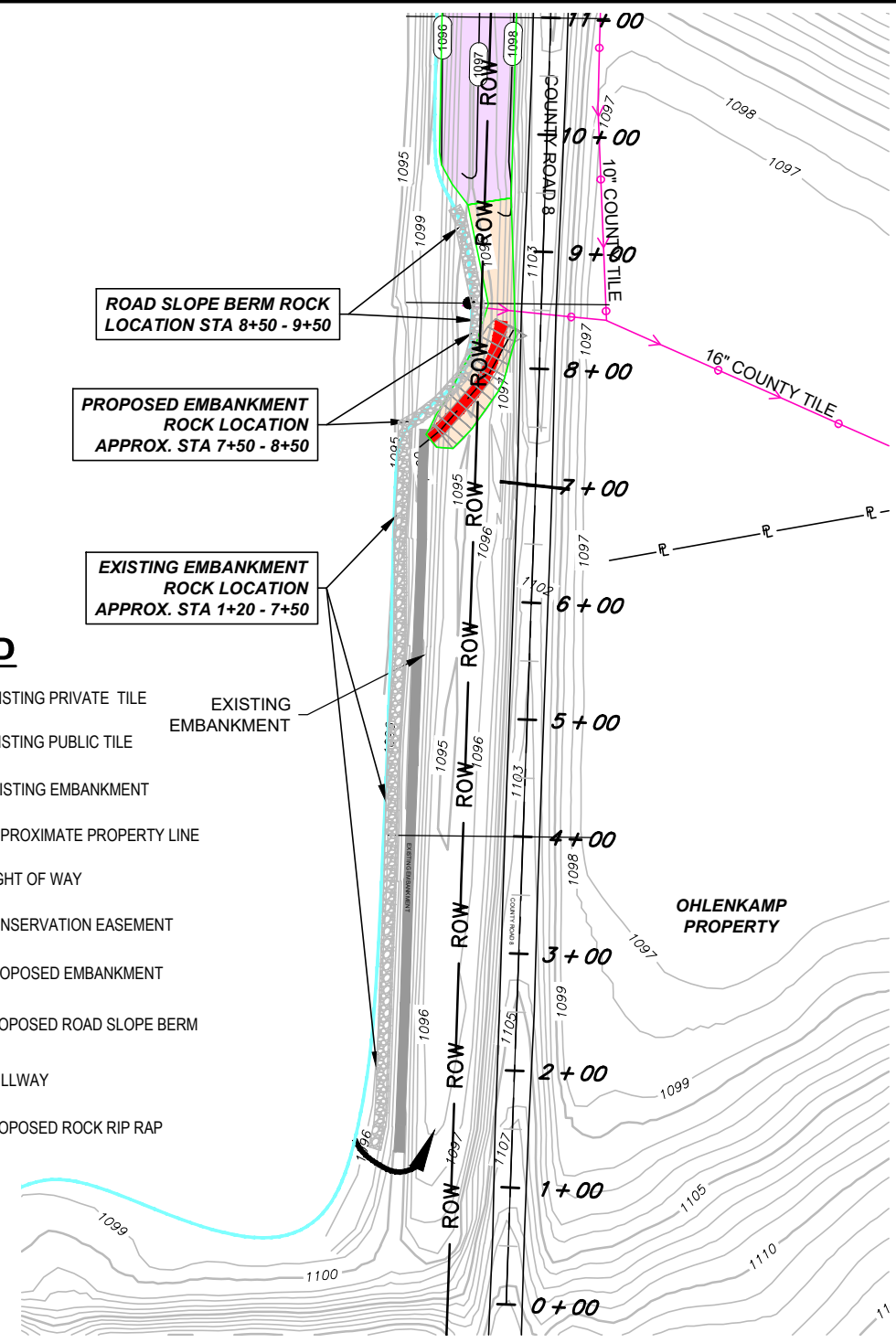

ESTIMATED QUANTITIES	UNIT	QUANTITY
MNDOT YPE IV GEOTEXTILE	SY	1460
2-4" BALLAST ROCK - RODENT PROTECTION	TONS	255
MNDOT CLASS II ROCK RIP RAP	TONS	510

I HEREBY CERTIFY THAT THIS PLAN, SPECIFICATION, OR REPORT WAS PREPARED BY ME OR UNDER MY DIRECT SUPERVISION AND THAT I AM A DULY LICENSED PROFESSIONAL ENGINEER UNDER THE LAWS OF THE STATE OF MINNESOTA.
 TERRY RAGAN
 DATE: 9/30/2021
 LIC. NO. 41163



HORSESHOE LAKE REPAIR - REDWOOD COUNTY
 REPAIR WETLAND RESTORATION
 ROCK SLOPE & RODENT PROTECTION

PROJECT #:
02409 REPAIR
 SHEET NO.
6 OF **9**

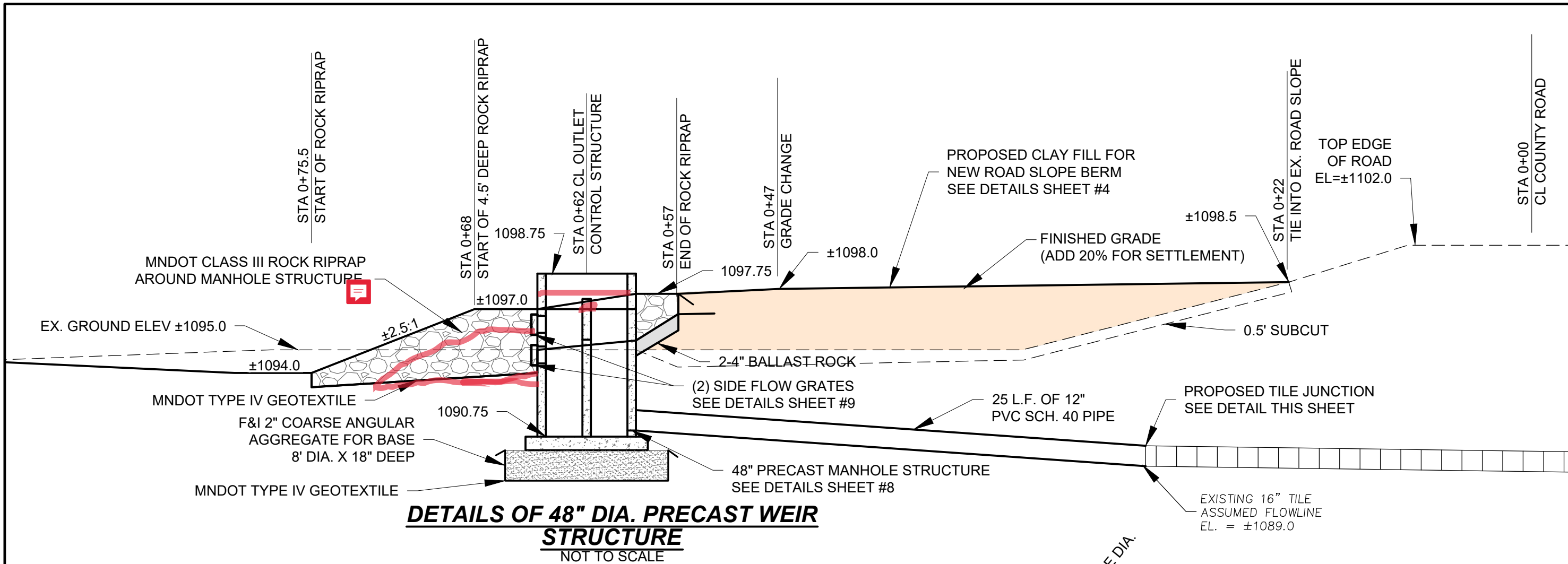

DETAILS OF 48" DIA. PRECAST WEIR STRUCTURE
NOT TO SCALE

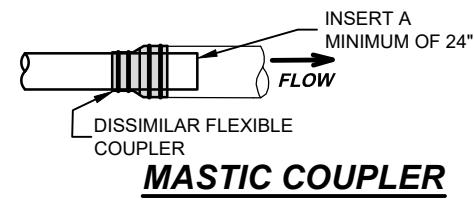

WATERTIGHT CONNECTION BETWEEN PRECAST WEIR WALL AND PRECAST MANHOLE WALL.

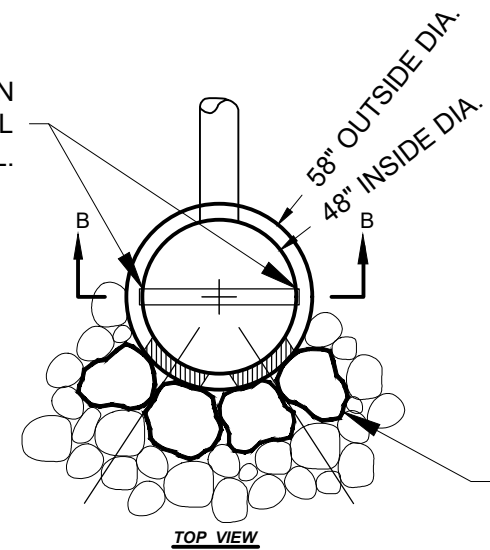

TYPICAL ROCK PLACEMENT FOR PRECAST STRUCTURE
NOT TO SCALE

CONSTRUCTION NOTE:
PLACEMENT OF ROCK RIPRAP IN FRONT OF 48" PRECAST STRUCTURE SHALL NOT TAKE PLACE UNLESS ENGINEER IS PRESENT. EXTREME CARE SHALL BE TAKEN IN PLACEMENT TO PREVENT DAMAGE TO AND TO NOT PLUG OPENINGS IN 48" PRECAST STRUCTURE. HAND PLACEMENT WILL BE REQUIRED TO ACHIEVE DESIRED RESULTS.

BILL OF MATERIALS	UNIT	QUANTITY
48" PRECAST MANHOLE BARREL W/OPENING FOR 12" SCH. 40 PVC PIPE W/ KEYWAY FOR 5" PRECAST WEIR WALL W/8" INTEGRAL BASE	LS	1
48" PRECAST MANHOLE UPPER SECTION W/ OPENINGS W/ KEYWAY 5" PRECAST WEIR WALL	LS	1
5" THICK CONCRETE WEIR WALL WITH WEIR OPENING	L.F.	6.75
SIDE FLOW GRATE (10" X 36" X 9" - 58" O.D. MANHOLE) - SEE DETAILS SHEET #8	LS	2
TOP HINGED W/LOCKING ROD FOR 48" MANHOLE - SEE DETAILS SHEET #8	LS	1
WATER TIGHT JOINTS (MASTIC) - MANHOLE SECTIONS & WEIR WALL	LS	1
12" SCHEDULE 40 PVC OUTLET PIPE (INCLUDES PIPE JUNCTIONS/FITTINGS)	LF	25
2" COARSE ANGULAR AGGREGATE FOR BASE	CY	4
MNDOT CLASS III ROCK RIP RAP	CY	10
MNDOT TYPE IV GEOTEXTILE	SY	19

I HEREBY CERTIFY THAT THIS PLAN, SPECIFICATION, OR REPORT WAS PREPARED BY ME OR UNDER MY DIRECT SUPERVISION AND THAT I AM A DULY LICENSED PROFESSIONAL ENGINEER UNDER THE LAWS OF THE STATE OF MINNESOTA.
 TERRY RAGAN DATE: 9/30/2021 LIC. NO. 41163



HORSESHOE LAKE REPAIR - REDWOOD COUNTY
 REPAIR WETLAND RESTORATION
 OUTLET STRUCTURE

PROJECT #:
02409 REPAIR
 SHEET NO.
7 OF 9

RCP MANHOLE NOTE: CONTRACTOR SHALL GET SHOP DRAWINGS APPROVED BY ENGINEER PRIOR TO ORDERING RCP MANHOLE STRUCTURE. IF POSSIBLE A MONOLITHIC RCP STRUCTURE IS PREFERRED. RCP MANHOLE FABRICATOR SHALL MINIMIZE NUMBER OF JOINTS IF POSSIBLE TO INSURE WATER TIGHTNESS. ALL RCP JOINTS SHALL BE WATER TIGHT AS DIRECTED BY ENGINEER (MASTIC IS AN APPROVED WATER TIGHT JOINT - MINIMUM 2 ROWS OR AS DIRECTED BY ENGINEER).

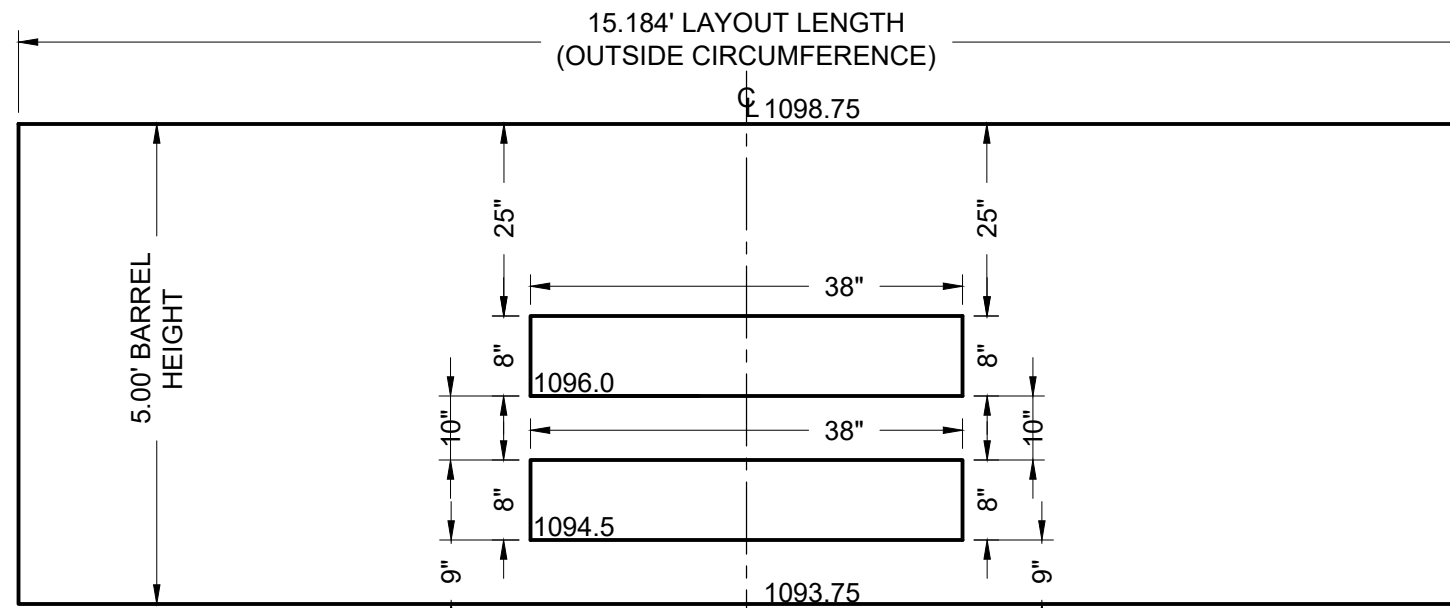

OPENING DETAILS OF 48" MANHOLE STRUCTURE

NOT TO SCALE

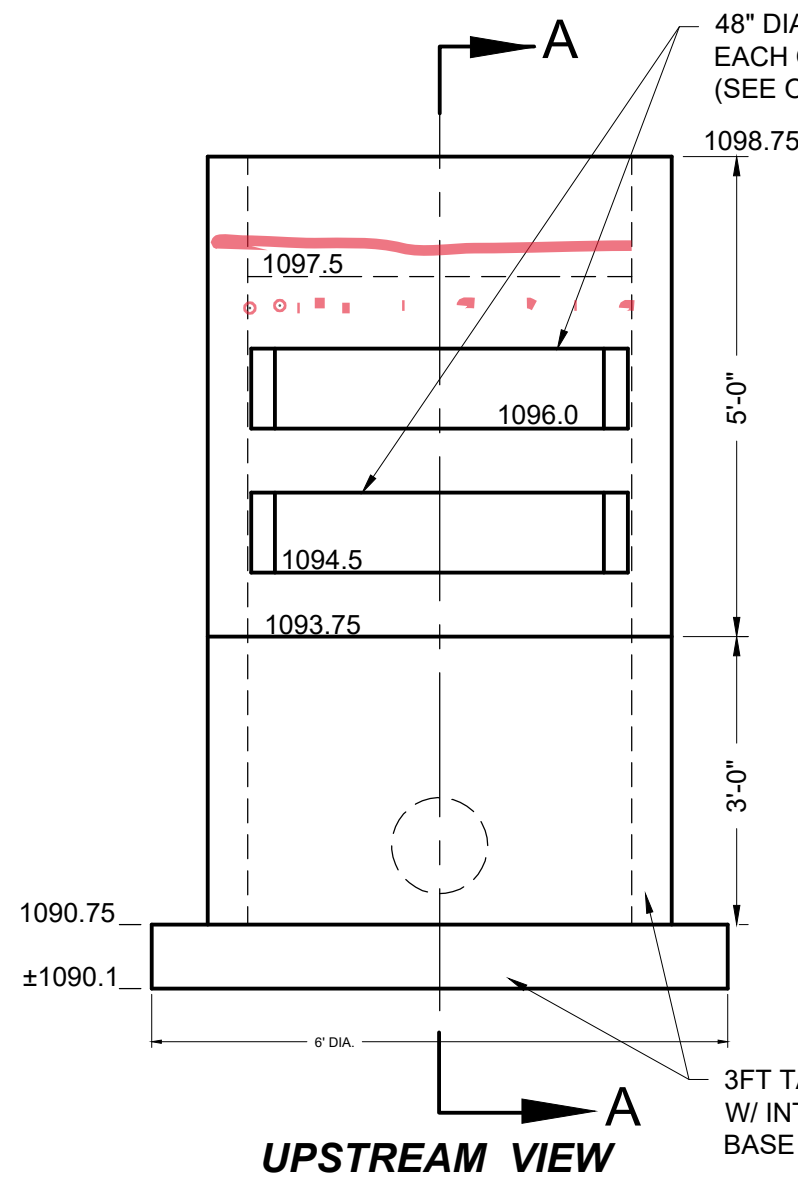

3FT TALL 48" PRECAST MANHOLE W/ INTEGRAL 6' DIA. CONCRETE BASE POURED 8" THICK

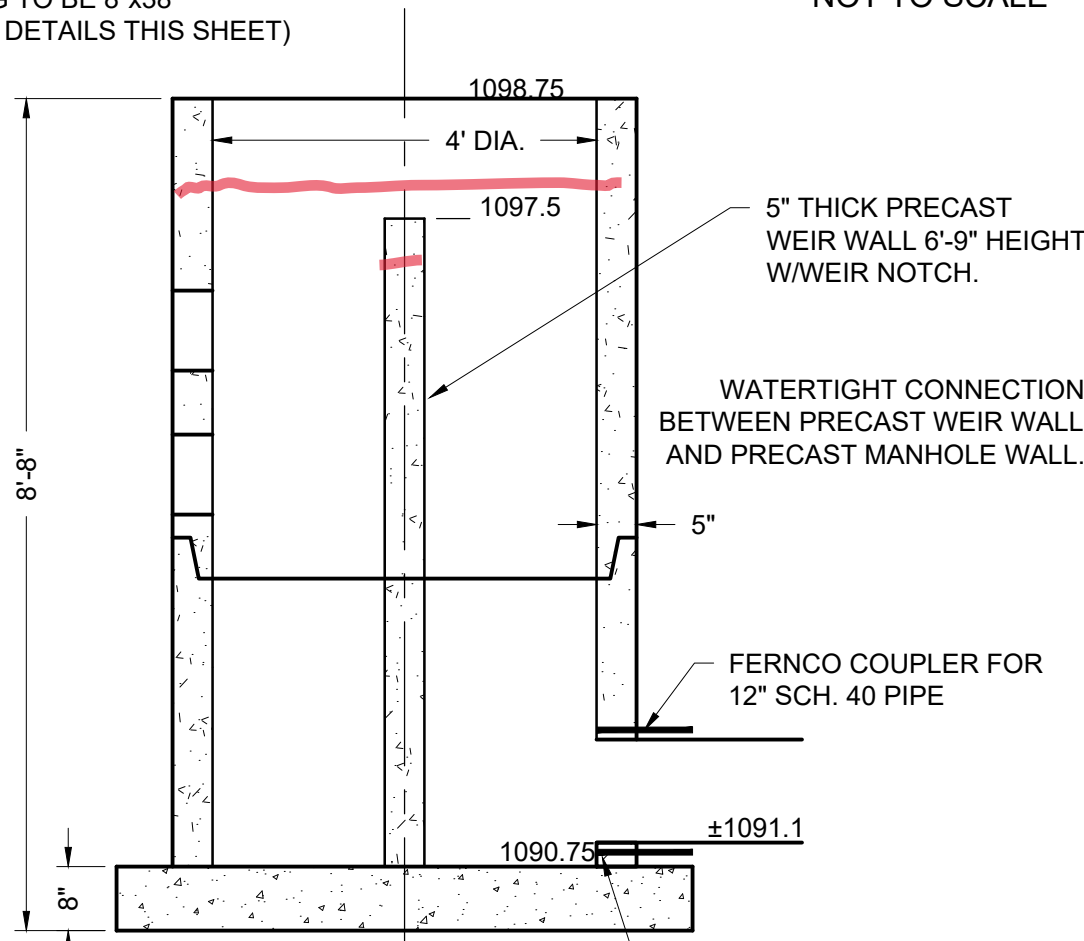

DETAILS OF 48" DIA. PRECAST WEIR STRUCTURE

NOT TO SCALE

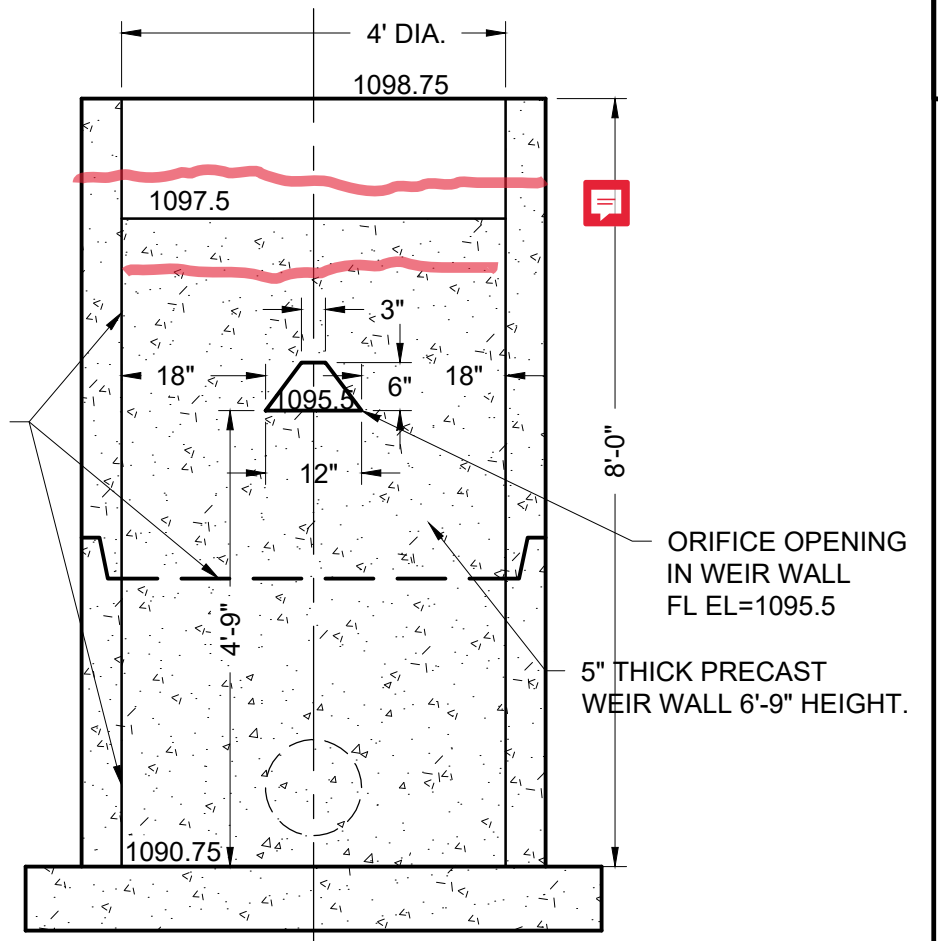

I HEREBY CERTIFY THAT THIS PLAN, SPECIFICATION, OR REPORT WAS PREPARED BY ME OR UNDER MY DIRECT SUPERVISION AND THAT I AM A DULY LICENSED PROFESSIONAL ENGINEER UNDER THE LAWS OF THE STATE OF MINNESOTA.

TERRY RAGAN
 DATE: 9/30/2021
 LIC. NO. 41163



HORSESHOE LAKE REPAIR - REDWOOD COUNTY
 REPAIR WETLAND RESTORATION
 48IN. PRECAST MANHOLE

PROJECT #:
 02409 REPAIR

SHEET NO.
 8 OF 9

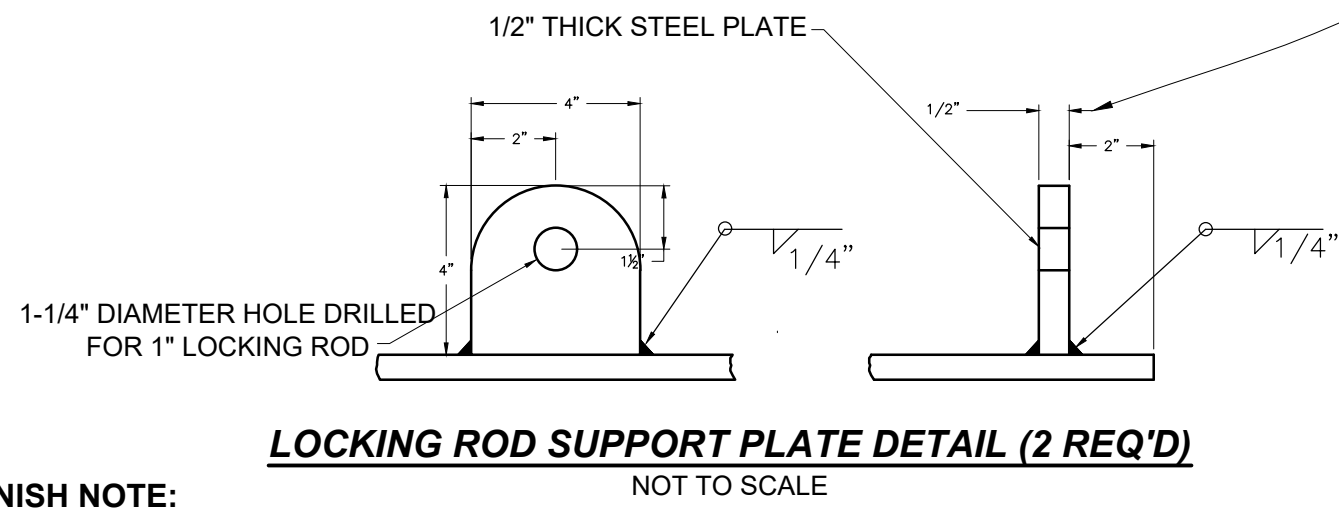
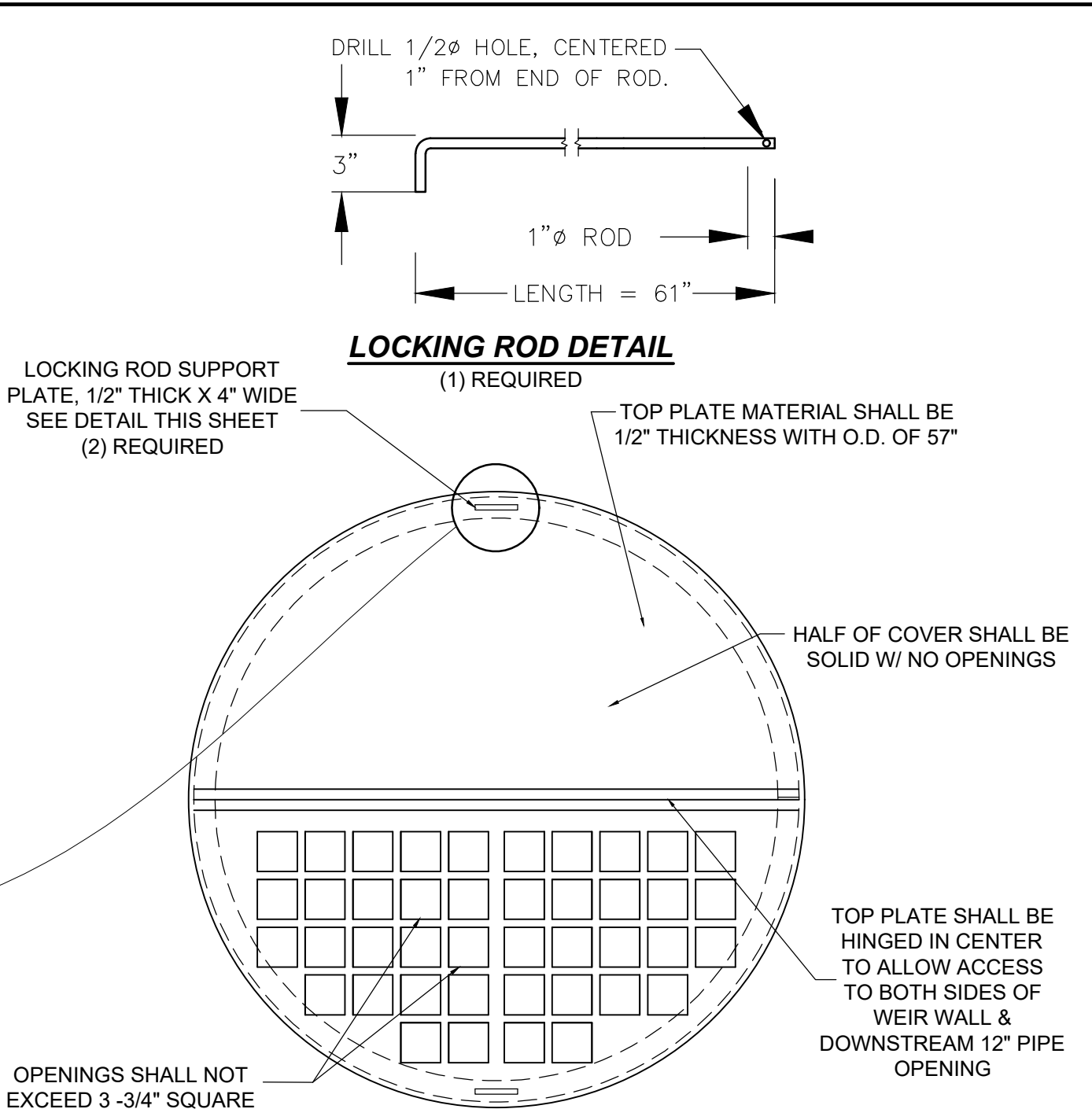
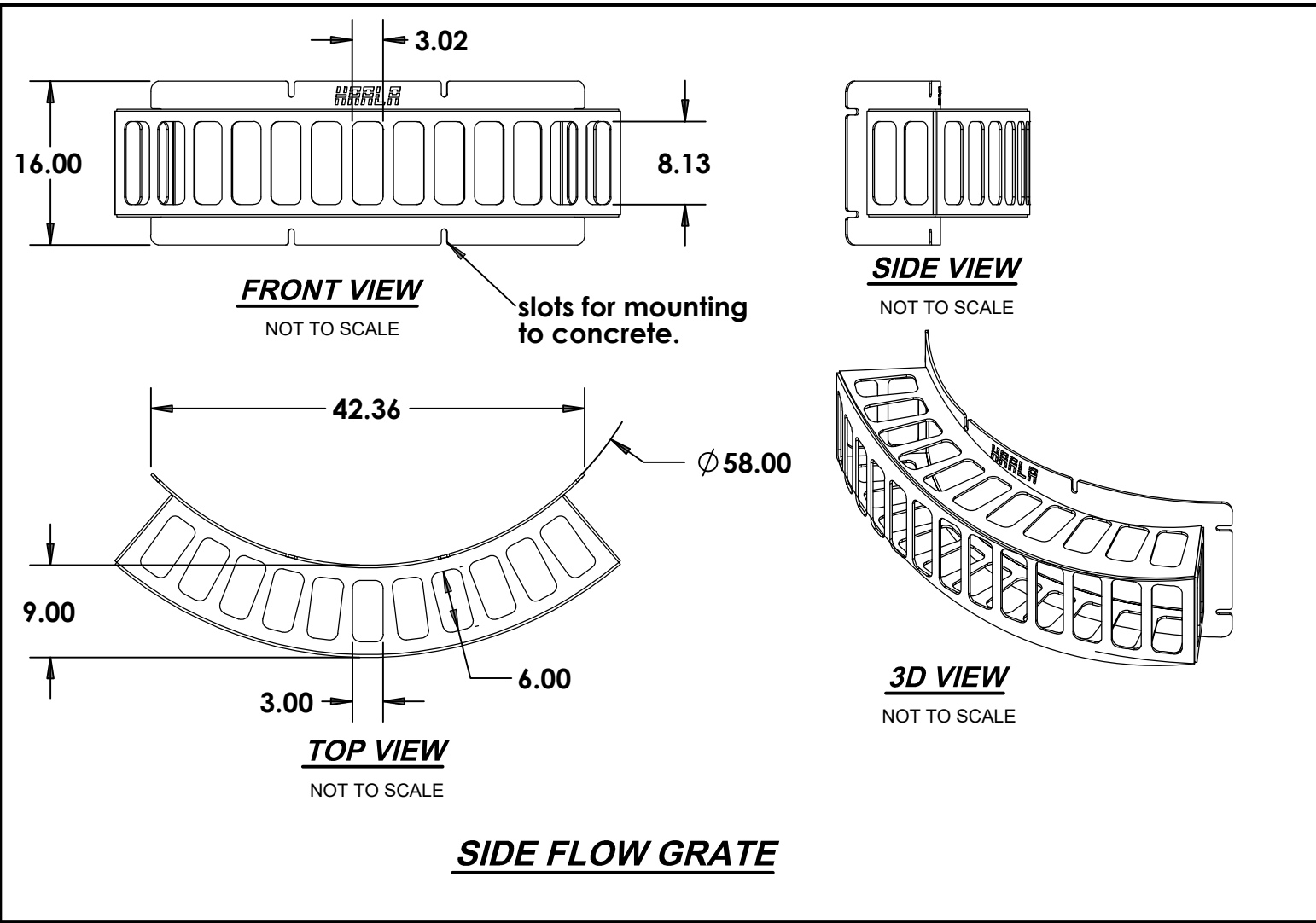

FINISH NOTE:
ALL STEEL ASSOCIATED WITH THE POND SKIMMER GRATE SHALL BE FINISHED TO PROTECT AGAINST CORROSION. FINISHING METHODS MAY INCLUDE GALVANIZED DIPPING (MNDOT SPEC. 3394, EDITION 2005), EPOXY ZINC-RICH COATING (MNDOT SPEC. 3520, EDITION 2005) POWDER WRINKLE COAT OR OTHER APPROVED METHOD. PRIOR TO FINISHING, ALL STEEL AND WELDED SURFACES SHALL BE CLEANED BY APPROVED METHODS, SEE ABOVE MNDOT SPECS.

APPROVED VENDOR:
HAALA INDUSTRIES, SLEEPY EYE MN. - WWW.HAALA.COM
OR APPROVED EQUAL

TOP GRATE

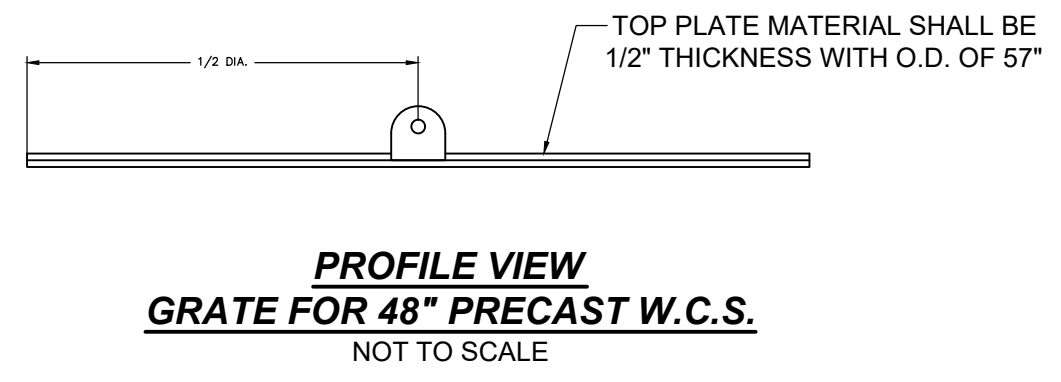

I HEREBY CERTIFY THAT THIS PLAN, SPECIFICATION, OR REPORT WAS PREPARED BY ME OR UNDER MY DIRECT SUPERVISION AND THAT I AM A DULY LICENSED PROFESSIONAL ENGINEER UNDER THE LAWS OF THE STATE OF MINNESOTA.

TERRY RAGAN
DATE: 9/30/2021
LIC. NO. 41163



HORSESHOE LAKE REPAIR - REDWOOD COUNTY
REPAIR WETLAND RESTORATION
SIDE FLOW GRATE & MANHOLE COVER

PROJECT #:
02409 REPAIR

SHEET NO.
9 OF 9



REQUEST FOR BOARD ACTION

Requested Board Date:	11-30-2021	Originating Dept.:	Technology Dept.
Preferred 2nd Date:			
Discussion Item:	Presenter: Paul Parsons		
Purchase Dell PC's	estimated time needed:	5-8 minutes	
Board Action:	<input checked="" type="checkbox"/> Yes, action required	<input type="checkbox"/> No, informational only	

If Action, Board Motion Requested:

Redwood County Commissioners: Please review and provide a decision to purchase 10 new PC's for Redwood County Staff. This will be part of a five year rotation for LEC, CH/JC, GC, Highway, GSB, and any others. These PC's in quote will have a three year warranty, plus on site repair if needed. This has been budgeted in the 6601 and/or the 6611 IT Budget. I would like to go with US_Quote_3000104767812.4 in the amount of \$6,730.00

Background Information:

This is a yearly thing.

Supporting Documents: Attached None

County Attorney Reviewed Information: Completed In Progress Not applicable

Administrators Comments:

Reviewed by Administrator: Yes No

**** The deadline for submitting items is 4:30 p.m. Wednesday prior to a Tuesday board day ****



A quote for your consideration

Based on your business needs, we put the following quote together to help with your purchase decision. Below is a detailed summary of the quote we've created to help you with your purchase decision.

To proceed with this quote, you may respond to this email, order online through your [Premier page](#), or, if you do not have Premier, use this [Quote to Order](#).

Quote No.	3000104767812.3	Sales Rep	Ramsey Alahmad
Total	\$8,100.00	Phone	(800) 456-3355, 6179204
Customer #	10786124	Email	Ramsey_Alahmad@Dell.com
Quoted On	Nov. 08, 2021	Billing To	ACCOUNTS PAYABLE
Expires by	Dec. 08, 2021		REDWOOD COUNTY
Contract Code	C000000181093		403 S MILL ST
Customer Agreement #	MHEC-07012015		REDWOOD FALLS, MN 56283-1671
Deal ID	20479628		

Message from your Sales Rep

Please contact your Dell sales representative if you have any questions or when you're ready to place an order. Thank you for shopping with Dell!

Regards,
Ramsey Alahmad

Shipping Group

Shipping To	Shipping Method
PAUL PARSONS REDWOOD COUNTY 403 S MILL ST REDWOOD FALLS, MN 56283-1671 (507) 637-1134	Standard Delivery

Product	Unit Price	Quantity	Subtotal
OptiPlex 5090 Small Form Factor	\$810.00	10	\$8,100.00
Subtotal:			\$8,100.00
Shipping:			\$0.00
Environmental Fee:			\$0.00
Non-Taxable Amount:			\$8,100.00
Taxable Amount:			\$0.00
Estimated Tax:			\$0.00
Total:			\$8,100.00

Shipping Group Details

Shipping To

PAUL PARSONS
 REDWOOD COUNTY
 403 S MILL ST
 REDWOOD FALLS, MN 56283-1671
 (507) 637-1134

Shipping Method

Standard Delivery

	Quantity	Subtotal
OptiPlex 5090 Small Form Factor	10	\$8,100.00

Estimated delivery if purchased today:
 Dec. 22, 2021
 Contract # C000000181093
 Customer Agreement # MHEC-07012015

Description	SKU	Unit Price	Quantity	Subtotal
OptiPlex 5090 SFF BTX	210-AYRZ	-	10	-
10th Generation Intel Core i7-10700 (8-Core, 16MB Cache, 2.9GHz to 4.8GHz, 65W)	338-BVCD	-	10	-
Windows 10 Pro English, French, Spanish	619-AHKN	-	10	-
No Microsoft Office License Included – 30 day Trial Offer Only	658-BCSB	-	10	-
16GB (2x8GB) DDR4 non ECC memory	370-AGFS	-	10	-
M.2 256GB PCIe NVMe Class 40 Solid State Drive	400-BLOQ	-	10	-
M.2 22x30 Thermal Pad	412-AAQT	-	10	-
M2X3.5 Screw for SSD/DDPE	773-BBBC	-	10	-
No Additional Hard Drive	401-AANH	-	10	-
Intel Integrated Graphics, Dell OptiPlex	490-BBFG	-	10	-
OptiPlex 5090 Small Form Factor with 200W up to 85% efficient Power Supply (80Plus Bronze), DAO, BCC	329-BFHS	-	10	-
System Power Cord (Philippine/TH/US)	450-AAOJ	-	10	-
No Optical Disk Drive	429-ABKF	-	10	-
CMS Software not included	632-BBBJ	-	10	-
No Media Card Reader	379-BBHM	-	10	-
No Wireless LAN Card (no WiFi enablement)	555-BBFO	-	10	-
No Wireless Driver (no WiFi enablement)	340-AFMQ	-	10	-
Chassis Intrusion Switch - SFF	461-AAEE	-	10	-
No Stand Option	575-BBBI	-	10	-
No Additional Cable Requested	379-BBCY	-	10	-
No PCIe add-in card	492-BBFF	-	10	-
No Additional Add In Cards	382-BBHX	-	10	-
No Additional Video Ports	492-BCKH	-	10	-
Dell KB216 Wired Keyboard English	580-ADJC	-	10	-
Dell Optical Mouse - MS116 (Black)	570-ABIE	-	10	-
No Cable Cover	325-BCZQ	-	10	-
Not selected in this configuration	817-BBBC	-	10	-
SupportAssist	525-BBCL	-	10	-
Dell(TM) Digital Delivery Cirrus Client	640-BBLW	-	10	-

Dell Client System Update (Updates latest Dell Recommended BIOS, Drivers, Firmware and Apps)	658-BBMR	-	10	-
Waves Maxx Audio	658-BBRB	-	10	-
Dell SupportAssist OS Recovery Tool	658-BEOK	-	10	-
Dell Optimizer	658-BEQP	-	10	-
Windows PKID Label	658-BFDQ	-	10	-
OS-Windows Media Not Included	620-AALW	-	10	-
ENERGY STAR Qualified	387-BBLW	-	10	-
SERI Guide (ENG/FR/Multi)	340-AGIK	-	10	-
Dell Watchdog Timer	379-BEKK	-	10	-
Quick Setup Guide 5090 SFF	340-CVFR	-	10	-
US Order	332-1286	-	10	-
Print on Demand Label	389-BDQH	-	10	-
Trusted Platform Module (Discrete TPM Enabled)	329-BBJL	-	10	-
Shipping Material for SFF	340-CQYR	-	10	-
Shipping Label	389-BBUU	-	10	-
MOD,LBL,REG,SFF,JSD2,200,5090	389-DZDJ	-	10	-
No Hard Drive Bracket, Dell OptiPlex	575-BBKX	-	10	-
Intel(R) Core(TM) i7 Processor Label	340-CNBW	-	10	-
Desktop BTS/BTP Shipment	800-BBIP	-	10	-
No Anti-Virus Software	650-AAAM	-	10	-
Fixed Hardware Configuration	998-EWIN	-	10	-
Speaker for Tower and SFF	520-AARD	-	10	-
No AutoPilot	340-CKSZ	-	10	-
EPEAT 2018 Registered (Silver)	379-BDTO	-	10	-
Intel Standard Manageability	631-ACYB	-	10	-
Dell Limited Hardware Warranty Plus Service	804-9043	-	10	-
ProSupport: 7x24 Technical Support, 3 Years	804-9050	-	10	-
ProSupport: Next Business Day Onsite 3 Years	804-9070	-	10	-
Thank you choosing Dell ProSupport. For tech support, visit //support.dell.com/ProSupport	989-3449	-	10	-

Subtotal:	\$8,100.00
Shipping:	\$0.00
Environmental Fee:	\$0.00
Estimated Tax:	\$0.00
Total:	\$8,100.00

Important Notes

Terms of Sale

This Quote will, if Customer issues a purchase order for the quoted items that is accepted by Supplier, constitute a contract between the entity issuing this Quote ("Supplier") and the entity to whom this Quote was issued ("Customer"). Unless otherwise stated herein, pricing is valid for thirty days from the date of this Quote. All product, pricing and other information is based on the latest information available and is subject to change. Supplier reserves the right to cancel this Quote and Customer purchase orders arising from pricing errors. Taxes and/or freight charges listed on this Quote are only estimates. The final amounts shall be stated on the relevant invoice. Additional freight charges will be applied if Customer requests expedited shipping. Please indicate any tax exemption status on your purchase order and send your tax exemption certificate to Tax_Department@dell.com or ARSalesTax@emc.com, as applicable.

Governing Terms: This Quote is subject to: (a) a separate written agreement between Customer or Customer's affiliate and Supplier or a Supplier's affiliate to the extent that it expressly applies to the products and/or services in this Quote or, to the extent there is no such agreement, to the applicable set of Dell's Terms of Sale (available at www.dell.com/terms or www.dell.com/oemterms), or for cloud/as-a-Service offerings, the applicable cloud terms of service (identified on the Offer Specific Terms referenced below); and (b) the terms referenced herein (collectively, the "Governing Terms"). Different Governing Terms may apply to different products and services on this Quote. The Governing Terms apply to the exclusion of all terms and conditions incorporated in or referred to in any documentation submitted by Customer to Supplier.

Supplier Software Licenses and Services Descriptions: Customer's use of any Supplier software is subject to the license terms accompanying the software, or in the absence of accompanying terms, the applicable terms posted on www.Dell.com/eula. Descriptions and terms for Supplier-branded standard services are stated at www.dell.com/servicecontracts/global or for certain infrastructure products at www.dellemc.com/en-us/customer-services/product-warranty-and-service-descriptions.htm.

Offer-Specific, Third Party and Program Specific Terms: Customer's use of third-party software is subject to the license terms that accompany the software. Certain Supplier-branded and third-party products and services listed on this Quote are subject to additional, specific terms stated on www.dell.com/offeringspecificterms ("Offer Specific Terms").

In case of Resale only: Should Customer procure any products or services for resale, whether on standalone basis or as part of a solution, Customer shall include the applicable software license terms, services terms, and/or offer-specific terms in a written agreement with the end-user and provide written evidence of doing so upon receipt of request from Supplier.

In case of Financing only: If Customer intends to enter into a financing arrangement ("Financing Agreement") for the products and/or services on this Quote with Dell Financial Services LLC or other funding source pre-approved by Supplier ("FS"), Customer may issue its purchase order to Supplier or to FS. If issued to FS, Supplier will fulfill and invoice FS upon confirmation that: (a) FS intends to enter into a Financing Agreement with Customer for this order; and (b) FS agrees to procure these items from Supplier. Notwithstanding the Financing Agreement, Customer's use (and Customer's resale of and the end-user's use) of these items in the order is subject to the applicable governing agreement between Customer and Supplier, except that title shall transfer from Supplier to FS instead of to Customer. If FS notifies Supplier after shipment that Customer is no longer pursuing a Financing Agreement for these items, or if Customer fails to enter into such Financing Agreement within 120 days after shipment by Supplier, Customer shall promptly pay the Supplier invoice amounts directly to Supplier.

Customer represents that this transaction does not involve: (a) use of U.S. Government funds; (b) use by or resale to the U.S. Government; or (c) maintenance and support of the product(s) listed in this document within classified spaces. Customer further represents that this transaction does not require Supplier's compliance with any statute, regulation or information technology standard applicable to a U.S. Government procurement.

For certain products shipped to end users in California, a State Environmental Fee will be applied to Customer's invoice. Supplier encourages customers to dispose of electronic equipment properly.

Electronically linked terms and descriptions are available in hard copy upon request.



A quote for your consideration

Based on your business needs, we put the following quote together to help with your purchase decision. Below is a detailed summary of the quote we've created to help you with your purchase decision.

To proceed with this quote, you may respond to this email, order online through your [Premier page](#), or, if you do not have Premier, use this [Quote to Order](#).

Quote No.	3000104767812.4	Sales Rep	Ramsey Alahmad
Total	\$6,730.00	Phone	(800) 456-3355, 6179204
Customer #	10786124	Email	Ramsey_Alahmad@Dell.com
Quoted On	Nov. 08, 2021	Billing To	ACCOUNTS PAYABLE
Expires by	Dec. 08, 2021		REDWOOD COUNTY
Contract Name	Dell Midwestern Higher Education Compact (MHEC) Master Agreement		403 S MILL ST REDWOOD FALLS, MN 56283-1671
Contract Code	C000000181093		
Customer Agreement #	MHEC-07012015		
Deal ID	20479628		

Message from your Sales Rep

Please contact your Dell sales representative if you have any questions or when you're ready to place an order. Thank you for shopping with Dell!

Regards,
Ramsey Alahmad

Shipping Group

Shipping To	Shipping Method
PAUL PARSONS REDWOOD COUNTY 403 S MILL ST REDWOOD FALLS, MN 56283-1671 (507) 637-1134	Standard Delivery

Product	Unit Price	Quantity	Subtotal
OptiPlex 5090 Small Form Factor	\$673.00	10	\$6,730.00

Subtotal:	\$6,730.00
Shipping:	\$0.00
Environmental Fee:	\$0.00
Non-Taxable Amount:	\$6,730.00
Taxable Amount:	\$0.00
Estimated Tax:	\$0.00
<hr/>	
Total:	\$6,730.00

Shipping Group Details

Shipping To

PAUL PARSONS
 REDWOOD COUNTY
 403 S MILL ST
 REDWOOD FALLS, MN 56283-1671
 (507) 637-1134

Shipping Method

Standard Delivery

	Quantity	Subtotal
OptiPlex 5090 Small Form Factor	10	\$6,730.00

Estimated delivery if purchased today:
 Dec. 22, 2021
 Contract # C000000181093
 Customer Agreement # MHEC-07012015

Description	SKU	Unit Price	Quantity	Subtotal
OptiPlex 5090 SFF BTX	210-AYRZ	-	10	-
Intel Core i5-10505 (6 Cores/12MB/12T/3.2GHz to 4.6GHz/65W); supports Windows 10/Linux	338-BZOV	-	10	-
Windows 10 Pro English, French, Spanish	619-AHKN	-	10	-
No Microsoft Office License Included – 30 day Trial Offer Only	658-BCSB	-	10	-
16GB (2x8GB) DDR4 non ECC memory	370-AGFS	-	10	-
M.2 256GB PCIe NVMe Class 35 Solid State Drive	400-BEUW	-	10	-
M.2 22x30 Thermal Pad	412-AAQT	-	10	-
M2X3.5 Screw for SSD/DDPE	773-BBBC	-	10	-
No Additional Hard Drive	401-AANH	-	10	-
Intel Integrated Graphics, Dell OptiPlex	490-BBFG	-	10	-
OptiPlex 5090 Small Form Factor with 200W up to 85% efficient Power Supply (80Plus Bronze), DAO, BCC	329-BFHS	-	10	-
System Power Cord (Philippine/TH/US)	450-AAOJ	-	10	-
No Optical Disk Drive	429-ABKF	-	10	-
CMS Software not included	632-BBBJ	-	10	-
No Media Card Reader	379-BBHM	-	10	-
No Wireless LAN Card (no WiFi enablement)	555-BBFO	-	10	-
No Wireless Driver (no WiFi enablement)	340-AFMQ	-	10	-
Chassis Intrusion Switch - SFF	461-AAEE	-	10	-
No Stand Option	575-BBBI	-	10	-
No Additional Cable Requested	379-BBCY	-	10	-
No PCIe add-in card	492-BBFF	-	10	-
No Additional Add In Cards	382-BBHX	-	10	-
No Additional Video Ports	492-BCKH	-	10	-
Dell KB216 Wired Keyboard English	580-ADJC	-	10	-
Dell Optical Mouse - MS116 (Black)	570-ABIE	-	10	-
No Cable Cover	325-BCZQ	-	10	-
Not selected in this configuration	817-BBBC	-	10	-
SupportAssist	525-BBCL	-	10	-
Dell(TM) Digital Delivery Cirrus Client	640-BBLW	-	10	-

Dell Client System Update (Updates latest Dell Recommended BIOS, Drivers, Firmware and Apps)	658-BBMR	-	10	-
Waves Maxx Audio	658-BBRB	-	10	-
Dell SupportAssist OS Recovery Tool	658-BEOK	-	10	-
Dell Optimizer	658-BEQP	-	10	-
Windows PKID Label	658-BFDQ	-	10	-
OS-Windows Media Not Included	620-AALW	-	10	-
ENERGY STAR Qualified	387-BBLW	-	10	-
SERI Guide (ENG/FR/Multi)	340-AGIK	-	10	-
Dell Watchdog Timer	379-BEKK	-	10	-
Quick Setup Guide 5090 SFF	340-CVFR	-	10	-
US Order	332-1286	-	10	-
Print on Demand Label	389-BDQH	-	10	-
Trusted Platform Module (Discrete TPM Enabled)	329-BBJL	-	10	-
Shipping Material for SFF	340-CQYR	-	10	-
Shipping Label	389-BBUU	-	10	-
MOD,LBL,REG,SFF,JSD2,200,5090	389-DZDJ	-	10	-
No Hard Drive Bracket, Dell OptiPlex	575-BBKX	-	10	-
Intel(R) Core(TM) i5 Processor Label	340-CNBZ	-	10	-
Desktop BTS/BTP Shipment	800-BBIP	-	10	-
No Anti-Virus Software	650-AAAM	-	10	-
Fixed Hardware Configuration	998-EWIJ	-	10	-
Speaker for Tower and SFF	520-AARD	-	10	-
No AutoPilot	340-CKSZ	-	10	-
EPEAT 2018 Registered (Silver)	379-BDTO	-	10	-
Intel Standard Manageability	631-ACYB	-	10	-
Dell Limited Hardware Warranty Plus Service	804-9043	-	10	-
ProSupport: 7x24 Technical Support, 3 Years	804-9050	-	10	-
ProSupport: Next Business Day Onsite 3 Years	804-9070	-	10	-
Thank you choosing Dell ProSupport. For tech support, visit //support.dell.com/ProSupport	989-3449	-	10	-

Subtotal:	\$6,730.00
Shipping:	\$0.00
Environmental Fee:	\$0.00
Estimated Tax:	\$0.00
Total:	\$6,730.00

Important Notes

Terms of Sale

This Quote will, if Customer issues a purchase order for the quoted items that is accepted by Supplier, constitute a contract between the entity issuing this Quote ("Supplier") and the entity to whom this Quote was issued ("Customer"). Unless otherwise stated herein, pricing is valid for thirty days from the date of this Quote. All product, pricing and other information is based on the latest information available and is subject to change. Supplier reserves the right to cancel this Quote and Customer purchase orders arising from pricing errors. Taxes and/or freight charges listed on this Quote are only estimates. The final amounts shall be stated on the relevant invoice. Additional freight charges will be applied if Customer requests expedited shipping. Please indicate any tax exemption status on your purchase order and send your tax exemption certificate to Tax_Department@dell.com or ARSalesTax@emc.com, as applicable.

Governing Terms: This Quote is subject to: (a) a separate written agreement between Customer or Customer's affiliate and Supplier or a Supplier's affiliate to the extent that it expressly applies to the products and/or services in this Quote or, to the extent there is no such agreement, to the applicable set of Dell's Terms of Sale (available at www.dell.com/terms or www.dell.com/oemterms), or for cloud/as-a-Service offerings, the applicable cloud terms of service (identified on the Offer Specific Terms referenced below); and (b) the terms referenced herein (collectively, the "Governing Terms"). Different Governing Terms may apply to different products and services on this Quote. The Governing Terms apply to the exclusion of all terms and conditions incorporated in or referred to in any documentation submitted by Customer to Supplier.

Supplier Software Licenses and Services Descriptions: Customer's use of any Supplier software is subject to the license terms accompanying the software, or in the absence of accompanying terms, the applicable terms posted on www.Dell.com/eula. Descriptions and terms for Supplier-branded standard services are stated at www.dell.com/servicecontracts/global or for certain infrastructure products at www.dellemc.com/en-us/customer-services/product-warranty-and-service-descriptions.htm.

Offer-Specific, Third Party and Program Specific Terms: Customer's use of third-party software is subject to the license terms that accompany the software. Certain Supplier-branded and third-party products and services listed on this Quote are subject to additional, specific terms stated on www.dell.com/offeringsspecificterms ("Offer Specific Terms").

In case of Resale only: Should Customer procure any products or services for resale, whether on standalone basis or as part of a solution, Customer shall include the applicable software license terms, services terms, and/or offer-specific terms in a written agreement with the end-user and provide written evidence of doing so upon receipt of request from Supplier.

In case of Financing only: If Customer intends to enter into a financing arrangement ("Financing Agreement") for the products and/or services on this Quote with Dell Financial Services LLC or other funding source pre-approved by Supplier ("FS"), Customer may issue its purchase order to Supplier or to FS. If issued to FS, Supplier will fulfill and invoice FS upon confirmation that: (a) FS intends to enter into a Financing Agreement with Customer for this order; and (b) FS agrees to procure these items from Supplier. Notwithstanding the Financing Agreement, Customer's use (and Customer's resale of and the end-user's use) of these items in the order is subject to the applicable governing agreement between Customer and Supplier, except that title shall transfer from Supplier to FS instead of to Customer. If FS notifies Supplier after shipment that Customer is no longer pursuing a Financing Agreement for these items, or if Customer fails to enter into such Financing Agreement within 120 days after shipment by Supplier, Customer shall promptly pay the Supplier invoice amounts directly to Supplier.

Customer represents that this transaction does not involve: (a) use of U.S. Government funds; (b) use by or resale to the U.S. Government; or (c) maintenance and support of the product(s) listed in this document within classified spaces. Customer further represents that this transaction does not require Supplier's compliance with any statute, regulation or information technology standard applicable to a U.S. Government procurement.

For certain products shipped to end users in California, a State Environmental Fee will be applied to Customer's invoice. Supplier encourages customers to dispose of electronic equipment properly.

Electronically linked terms and descriptions are available in hard copy upon request.



REQUEST FOR BOARD ACTION

Requested Board Date:	11/30/2021	Originating Dept.:	A/T
Preferred 2nd Date:			
Discussion Item:	Presenter:		
Resolution approving Redwood County's Application for Funding from the Voting Equipment Grant Application (VEGA-3)	estimated time needed:	5 min	
Board Action: <input checked="" type="checkbox"/> Yes, action required <input type="checkbox"/> No, informational only			

If Action, Board Motion Requested:

Motion to approve the resolution approving Redwood County's Application for Funding from the Voting Equipment Grant (VEGA-3)

Background Information:

Redwood County needs to replace 13 automark machines purchased in 2006 with the Omni Ballot Tablet for \$4,300/machine. This grant could potentially pay for up to 50% of the machine cost with the potential of receiving another Voter Grant that will be coming out in 2022 from the Secretary of State to help pay for our 50%. If that grant is not approved, then our 50% portion or whatever portion we will be responsible for, will come out of the election reserve fund. Redwood County will also be asking for 50% of the upgrade to ElectionWare that was approved by the board and paid for in September of 2021 in the amount of \$6,161.

Supporting Documents: Attached None

County Attorney Reviewed Information: Completed In Progress Not applicable

Administrators Comments:

Reviewed by Administrator: Yes No

**** The deadline for submitting items is 4:30 p.m. Wednesday prior to a Tuesday board day ****

Redwood County Board of Commissioners

403 South Mill Street
P.O. Box 130
Redwood Falls, MN 56283
Phone: (507) 637-4016 Fax: (507) 637-4017
redwoodcounty-mn.us



**RESOLUTION APPROVING REDWOOD COUNTY'S APPLICATION FOR FUNDING
FROM THE 2021 VOTING EQUIPMENT GRANT (VEGA-3)**

WHEREAS, Minnesota counties are responsible for administering elections, which includes the purchase and maintenance of supplies and election equipment, including accessible voting equipment; and

WHEREAS, it's essential for precincts to have functioning voting equipment so that voters are able to cast their ballot on equipment that is secure, accessible, accurate, and reliable; and

WHEREAS, Minnesota Statutes section 206.95 is intended to help political subdivisions purchase optical scan assistive voting devices (AVDs), optical scan ballot counters, electronic rosters and other related items that qualify as election equipment under Minnesota Statutes section 206.56, subdivision 8; and

WHEREAS, to receive funding from the Voting Equipment Grant Account (VEGA-3), counties must submit an application to the Minnesota Secretary of State by 4:00 p.m. on Friday, December 17, 2021; now, therefore,

BE IT RESOLVED, Redwood County approves its application for funding from the Voting Equipment Grant (VEGA-3) and hereby authorizes the Auditor/Treasurer to submit and execute the grant application on behalf of Redwood County; and

BE IT FURTHER RESOLVED, the County certifies that any funds awarded from the Voting Equipment Grant will be used only to purchase assistive voting technology, an electronic roster system, an electronic voting system, any individual component of an electronic voting system, or any other equipment or technology approved by the Secretary of State.

Passed and adopted by the Redwood County Board of Commissioners this 30th day of November, 2021.

BOARD OF COMMISSIONERS
REDWOOD COUNTY, MN

Jim Salfer, Board Chair

ATTEST: _____

Vicki Kletscher,
County Administrator

1st District
RICK WAKEFIELD
P.O. Box 473
Walnut Grove, MN 56180
(507) 859-2369
Rick_W@co.redwood.mn.us

2nd District
JIM SALFER
865 Pine Street
Wabasso, MN 56293
(507) 342-2431
Jim_S2@co.redwood.mn.us

3rd District
DENNIS GROEBNER
250 Center Street
Clements, MN 56224
(507) 692-2235
Dennis_G@co.redwood.mn.us

4th District
BOB VANHEE
503 Fallwood Road
Redwood Falls, MN 56283
(507) 616-1000
Bob_V@co.redwood.mn.us

5th District
DAVE FORKRUD
P.O. Box 235
Belview, MN 56214
(507) 430-1907
Dave_F@co.redwood.mn.us

2022 Liquor License Application

Redwood County, Minnesota

Grandview Valley Winery Inc

-Swedes Forest

Board of Commissioner's Approval

County Auditor Approval

No. 64-22-15
Fee \$ 850.00



County REDWOOD

COUNTY LIQUOR LICENSE - "ON SALE"

THIS CERTIFIES THAT:

LICENSEE GRANDVIEW VALLEY WINERY INC

TRADE NAME GRANDVIEW VALLEY WINERY

STREET ADDRESS OR LOT AND BLOCK NO 42703 GRANDVIEW AVE BEL VIEW MN 56214

Is authorized to sell intoxicating liquor at on sale subject to the laws and regulations of the State of Minnesota and municipal ordinances for the period beginning 12/01/2021 to 12/01/2022

THIS LICENSE IS APPROVED

Alcohol & Gambling Enforcement Director Date

Chair Person or President
Given under my hand and the Corporate Seal of

Date

CLERK or Recorder



REQUEST FOR BOARD ACTION

Requested Board Date:	November 16, 2021	Originating Dept.:	Admin
Preferred 2nd Date:			
Discussion Item:	Presenter: Vicki K		
Alpha Media Lease Agreement	estimated time needed:	5 min	
Board Action: <input checked="" type="checkbox"/> Yes, action required <input type="checkbox"/> No, informational only			

If Action, Board Motion Requested:

Approve lease agreement with Alpha Media

Background Information:

Renewal of 5 year lease agreement, previous amount was \$1,300.
New terms \$1,500 annually and another 5 year term

Supporting Documents: Attached None

County Attorney Reviewed Information: Completed In Progress Not applicable

Administrators Comments:

Reviewed by Administrator: Yes No

**** The deadline for submitting items is 4:30 p.m. Wednesday prior to a Tuesday board day ****

LEASE AND AGREEMENT

This Agreement is made and entered into by and between the County of Redwood, a political subdivision of the State of Minnesota (hereinafter referred to as "County"), and Alpha Media (hereinafter referred to as "Lessee").

WHEREAS, Lessee is a duly organized corporation duly organized registered to do business in the State of Minnesota; and

WHEREAS, Lessee has the authority to execute this Agreement as a binding legal obligation, fully enforceable in accordance with its terms and conditions; and

WHEREAS, the County has the power and right to enter into this Agreement.

NOW, THEREFORE, in consideration of the rents, covenants and mutual undertakings of the parties hereinafter set forth, the County does hereby lease and let to Lessee, and the Lessee does hereby hire and take from the County the following described tract of real estate lying and being in Redwood County Minnesota, to wit:

All that part of Lots Number 8 and IO of Auditor's Subdivision Number 1 of Section 36, Township 1 13N, Range 36 West described as follows:

Beginning at a point 3 28.2 feet west of the East line of Lot Number 8 of Auditor's Subdivision No. 1 of said Section 36, which is located on the centerline of Minnesota Trunk I highway Number 19; thence at right angles in a northerly direction a distance of 305 feet to the point of beginning. From said point of beginning in a northerly direction a distance of 165 feet; thence North 61 degrees 92 minutes 75 seconds West a distance of 510 feet; thence in a southerly direction a distance of 405 feet; thence in an easterly direction, parallel to the centerline of said highway a distance of 450 feet to the place of beginning, containing 2.94 acres, more or less.

for the purpose of constructing, installing, using, operating and maintaining thereon a radio transmitting tower and a studio-transmitter building, together with all structures, facilities, equipment, wiring system and the like deemed necessary or expedient by Lessee for the operation of its radio broadcasting station for a term of five (5) years from and after the first day of January, 2022, yielding and paying therefor a rent of One Thousand Five Hundred and NO/100 Dollars (\$1,500.00) per year, to be paid on or before January 1 each year, in advance.

IT IS COVENANTED AND AGREED by and between the County and Lessee as follows:

1. Lessee shall pay the rent as set forth above annually on or before the first day of January in each year during the term of this Lease. The County shall submit a bill for said rentals to Lessee at least thirty (30) days before said rentals are due.

2. Any and all rent payments received subsequent to the first day of January in violation of Section 1 herein shall be subject to a penalty of \$50 per month.
3. Lessee shall quietly and peaceably enjoy the exclusive right to possession and occupancy of the leased premises subject to the modifications of such use and occupancy hereinafter set forth.
4. The County may mow and remove all hay grown on said premises but shall use due care at all times not to damage or interfere with Lessee's installations and operations.
5. The County will and does hereby grant to Lessee, its successors and persons lawfully entering upon the leased premises the right, privilege and easement to use the County Highway along the East line of the leased premises for ingress thereto and egress therefrom for and during the term of this lease.
6. Lessee shall have the right at any time from and after the date hereof to cancel this lease for the reason that the Federal Communications Commission ("FCC") has refused or has not for any reason issued to Lessee a permit to remove the location of its transmitting tower from its present location to the leased premises, or that the FCC has cancelled, revoked, annulled, refused or failed for any reason to renew any and all licenses or permits required for the operation of Lessee's broadcasting station at or near Redwood Falls, Minnesota. Lessee may effect such cancellation by giving at least thirty (30) days' written notice to the County of its intention to so cancel this lease at any time.
7. Upon termination of this lease or cancellation pursuant to its terms, Lessee shall have the right, but not the duty, for a period of six (6) months after said termination, or after the effective date of cancellation hereof, of entering upon the leased premises and severing and removing therefrom any or all of its property located thereon including, but not limited to, buildings, towers, structures, poles, wires and improvements. In any event, Lessee shall restore the affected area or areas as nearly as may be it to its or their natural condition or shall reimburse the County for the costs of said restoration. If Lessee fails to remove all property with the time limits herein, said property shall become the property of the County.
8. None of the property of Lessee located or constructed on the leased premises shall become real estate but shall be and remain personal property.
9. Lessee shall at all times during the terms of this Lease keep in full force and effect a policy or policies of public liability and property damage insurance generally known as owners, landlord's and tenant's liability insurance covering the leased premises with coverages of at least \$1,000,000 per person, \$1,000,000 per occurrence, and \$1,000,000 for property damage. Said policy or policies shall name the County as an additional insured, and Lessee shall furnish the County on or before January 1, 2022, with a certificate or certificates of insurance showing that said insurance is in full force and effect.

10. Lessee shall keep and maintain the leased premises during the term of this Lease and quit and deliver the same to the County peaceably and quietly at the end of the aforementioned term or at any previous termination thereof for any cause.
11. Lessee shall keep said premises continually in a neat, clean and respectable condition, including mowing, and will at its expense remove therefrom all garbage or refuse of any kind and will not permit any waste thereon or thereof and will not assign or sublet said premises or any part thereof without the written consent of the County. Except for weed control, lessee's obligations under this section do not extend to those areas immediately surrounding the radio tower.
12. Lessee shall be solely responsible for all water, light, heat, gas, sewer or garbage service, and any and all other utilities used on the leased premises by Lessee.
13. Lessee agrees to indemnify and hold harmless the County and its officers, officials, agents, volunteers and employees from any liability, claims, losses, damages, costs, judgments, or expenses, including reasonable attorneys' and other professional fees, resulting directly or indirectly from any negligent, tortious or illegal act or omission, including without limitation, professional errors or omissions by the Lessee arising from the use of the property pursuant to this Lease, and against all loss by reason of the failure of the Lessee to fully to perform all obligations under this Lease. The terms and provisions of this Section 13 shall survive the expiration, suspension or termination of this Agreement.
14. In addition to the penalties described in Section 2 herein, if the rent specified herein, whether the same be demanded or not, is not paid when the same becomes due, or if the leased premises shall be appropriated to or used for any other purpose or use than hereinbefore specified or if said premises, or any part thereof, shall be sublet or this lease be assigned without the written consent of the County, or if any term, condition or covenant of this lease to be by Lessee kept or performed shall be violated or neglected, then Lessee does hereby authorize and fully empower the County or its agent to cancel and annul this lease at once and to re-enter and take possession of said premises immediately and by force, if necessary, without any previous notice or intention to re-enter, and remove all persons and their property therefrom and to use such force and assistance in effecting and perfecting such removal as the County may deem advisable to recover at once the full and exclusive possession of all the leased premises, whether in the possession of Lessee or of third persons or vacant, or the County or its agent may at its option at any time after such default or violation of condition or covenant re-enter and take possession of the leased premises without such re-entry working a forfeiture of the rents to be paid and the covenants to be kept by Lessee for the full term of this Lease.
15. Any alterations, variations, modifications, or waivers of the provisions of this Lease shall only be valid when they have been reduced to writing and signed by authorized representatives of the County and Lessee. Any assignment or sublet of this lease shall not be valid without the prior written consent of the County.

16. This Lease is the final expression of the agreement of the parties and the complete and exclusive statement of the terms agreed upon, and shall supersede all prior negotiations, understanding or agreements. There are no representations, warranties, or stipulations, either oral or written, not herein contained.

17. All of the covenants, terms and conditions of this Lease shall extend, apply to and firmly bind the successors and assigns of Lessee and the County as fully as the said parties are themselves bound. Any assignment pursuant to the terms of this Lease shall be subject to all the covenants, terms and conditions of this Lease.

IN WITNESS WHEREOF, the parties have executed this instrument on the date and year so indicated.

COUNTY OF REDWOOD:

Chair, Board of Commissioners

Date: _____

Redwood County Administrator

Date: _____

ALPHA MEDIA:

OBO Alpha Media

Date: _____

APPROVED AS TO FORM
Redwood County Attorney

By:  _____

Date: 10.29.2021 _____



REQUEST FOR BOARD ACTION

Requested Board Date:	November 30, 2021	Originating Dept.:	Admin
Preferred 2nd Date:			
Discussion Item:		Presenter:	Vicki K
AREA II JPA		estimated time needed:	5 min
Board Action:		<input checked="" type="checkbox"/> Yes, action required <input type="checkbox"/> No, informational only	

If Action, Board Motion Requested:

Authorize the Delegate member to the revised Joint Powers Agreement at the next Area II Board meeting.

Background Information:

The only change to the JPA is the date. Commissioner Wakefield is the AREA II delegate and your approval at our Board meeting will authorize him to sign the JPA at the next AREA II Board meeting scheduled for December 2, 2021

Supporting Documents: Attached None

County Attorney Reviewed Information: Completed In Progress Not applicable

Administrators Comments:

Reviewed by Administrator: Yes No

**** The deadline for submitting items is 4:30 p.m. Wednesday prior to a Tuesday board day ****

**A JOINT AND COOPERATIVE AGREEMENT
FOR THE CONTINUING OPERATION OF**

**AREA II MINNESOTA RIVER BASIN PROJECTS
AS A JOINT POWERS ENTITY
UNDER MINNESOTA STATUTES § 471.59**

I. INTENT OF AGREEMENT

The intent of this agreement is to maintain an organization in the form of a Joint Powers Entity, as authorized by Minnesota Statutes §471.59, which will carry on a program of floodwater retention and retardation measures, both structural and nonstructural, in the drainage area outletting into the south side of the Minnesota River between the cities of Ortonville and Mankato, Minnesota. This area is known as Study Area II in the Minnesota River Basin Report developed by the Minnesota Board of Water and Soil Resources. The information from this report recommended a program of structural measures including 81 flood retarding structures and 10.1 miles of levees. Nonstructural measures including, but not limited to, accelerated land treatment, conservation farming practices, floodplain zoning, groundwater quality enhancement, environmental corridors, and water quality improvement were also shown to be a necessary part of a flood damage reduction program. The joint Soil Conservation Service/Corps of Engineers P.L. 87-639 Study completed on these subbasins demonstrated that both structural and nonstructural components must be a part of effective flood control in this area.

Because the flooding problems in these watershed areas are interconnected due to the topography of the area, an area-wide solution is necessary and toward this end, this nine (9) county joint powers agreement is addressed.

II. JOINT AND COOPERATIVE AGREEMENT

The parties to this agreement are county governments within the State of Minnesota which govern lands draining water into the Minnesota River or its tributaries within the defined boundaries of Area II. These nine counties share the interest and goal of reducing flood damages along this reach of the Minnesota River and along tributaries to it wholly or partly within their individual boundaries. The parties to this agreement realize that the success of this flood control program is dependent upon the sincere desire of each participant to cooperate in the exercise of joint powers to solve a joint problem and pledge to do so.

The signatories to this agreement all have the power to construct, reconstruct, extend, maintain, and manage flood control facilities. The signatories also have the power to enact and enforce floodplain and land use rules in this area. The signatories have developed individual Comprehensive Local Water Plans under Minnesota law and they pledge that projects undertaken

under this agreement will be in conformance with these plans. This agreement is made pursuant to the authority conferred upon the participants by Minnesota Statutes § 471.59, and whatever other portions of the Statutes are applicable both now and in the future.

It is recognized by the participating parties that the upper reaches of this flood control area lay within the jurisdiction of the State of South Dakota. A significant portion of the water which must be controlled originates there. Since these South Dakota counties cannot join directly into this joint powers agreement, the participants pledge to cooperate with legal entities established in South Dakota directed toward these same goals.

III. ESTABLISHMENT OF THE BOARD OF DIRECTORS

For the purpose of accomplishing the objectives and intent of this agreement, the participants hereto do hereby establish the Area II Minnesota River Basin Projects Board of Directors (“Board”), as authorized by Minnesota Statutes § 471.59. The Board shall consist of one member from each of the counties in this agreement. The geographical jurisdiction of the Board shall be coextensive with that part of the geographical boundaries of each of the participants to this agreement, which lie within the watershed of the Minnesota River, and are a part of Study Area II of the Minnesota River Basin as established by the Minnesota Board of Water and Soil Resources.

IV. DEFINITIONS

For the purpose of this agreement, the terms used herein shall have the meaning as defined in this article.

Subdivision 1. “Participant” means a county of the State of Minnesota signed to this agreement.

Subdivision 2. “Board” means the Board of Directors created by this agreement, consisting of one member from each of the counties participating in this agreement. The full name of the Board is: “Area II Minnesota River Basin Projects Board.”

Subdivision 3. “Appointing Board” means the Board of Commissioners of the county which is a Participant to this agreement.

Subdivision 4. “Area II” means Area II Minnesota River Basin Projects, a Joint Powers Entity.

V. MEMBERSHIP

The membership of the Board shall consist of the duly appointed representatives of the following Minnesota counties as shall elect, through resolution or ordinance adopted by their respective governing bodies, to become members:

Brown County
Cottonwood County
Lac qui Parle County

Lincoln County
Lyon County
Murray County

Pipestone County
Redwood County
Yellow Medicine County

The South Dakota counties recognized by this agreement having part of their areas within Area II are:

Brookings County
Codington County

Deuel County
Grant County

No change in geographic boundaries, structure, or organization data shall affect the eligibility of any county listed above to be represented on the Board, so long as such county continues to exist as a separate political subdivision.

Each member of the Board shall have one (1) vote.

VI. BOARD OF DIRECTORS

Subdivision 1. The Board shall consist of the same number of members as there are counties participating in this agreement. Each participating county shall have one member to be appointed by that county's Board of Commissioners. Each Appointing Board shall also appoint an alternate member who shall serve and be entitled to vote in the regular member's absence.

Subdivision 2. The Appointing Boards shall choose a delegate and an alternate member who shall be a member of the Appointing Board and a commissioner of the participating county. The terms of each member and alternate appointed shall be established by this agreement. Only delegate members are entitled to vote and make motions. Only in the absence of the delegate is the alternate given these responsibilities, however, alternate members are encouraged to attend for discussion participation.

Subdivision 3. The Appointing Board of each participant to this agreement agrees that its representative member or alternate once appointed shall serve until removed by the Appointing Board.

Subdivision 4. Board members may receive compensation and reimbursement of their expenses from Area II funds for Executive Board or special meetings.

Subdivision 5. Each Appointing Board shall, within thirty (30) days of appointment of a member or alternate, file with the Secretary/Treasurer of Area II, a record of the appointment of its representative member and alternate.

VII. POWERS AND DUTIES OF THE BOARD

Subdivision 1. An organizational meeting of the Board shall be held forthwith upon appointment of all members. At this meeting the appointed members shall become members of the Area II Board, and they shall adopt such rules and regulations governing Board meetings as well as place and frequency of such meetings. Such rules and regulations may be amended from time to time at either a regular or special meeting of the Board provided that a ten (10) day prior notice of the proposed amendment has been furnished to each person to whom notice of a Board meeting is required to be sent; a majority vote of all eligible members shall be sufficient to adopt any proposed amendments to such rules and regulations.

Subdivision 2. At the organizational meeting and in January of each odd-numbered year thereafter, the Board shall meet and elect from its members: a Chairman, a Vice Chairman, and a Secretary/Treasurer to conduct its meetings and affairs, and to be the Executive Board of Directors of Area II. Each term is a two-year commitment with a maximum of two consecutive terms in the Executive Board position.

Subdivision 3. The Executive Board will provide overall policy direction to Area II's Board of Directors.

Subdivision 4. The Board will select from an array of plans prepared by the Area II staff that plan which will most equitably distribute the cost of the flood damage reduction program over the participant counties for the term of the Joint Powers Agreement and as attached to and becomes part of this binding agreement.

Subdivision 5. The Executive Board may exercise all of the powers authorized under Chapter 471.59 of Minnesota Statutes given to a county which are consistent with the purposes and intent of this agreement.

Subdivision 6. The Board shall comply with the requirements of Chapter 13D of Minnesota Statutes (Open Meeting Law).

VIII. POWERS AND DUTIES OF AREA II

Subdivision 1. Area II shall, as it relates to flood control, water conservation and supply, groundwater protection and enhancement, construction of related facilities, and facilitating other flood control efforts in this area, have the powers and duties set forth in this article.

Subdivision 2. Area II may employ such persons on a full-time, part-time, or consulting basis as Area II deems necessary.

Subdivision 3. Area II may contract for and acquire necessary personal property to carry out its powers and duties.

Subdivision 4. Area II may make necessary surveys or utilize other reliable surveys and data and develop projects to accomplish the purpose and intent of this agreement.

Subdivision 5. Area II may cooperate or contract with any state or subdivision thereof, federal agencies of the United States, private or public corporations, or cooperative associations. Area II may also cooperate with private individuals.

Subdivision 6. Area II may establish and maintain devices for acquiring and recording hydrological data.

Subdivision 7. Area II may apply for and accept funds from the federal government and other governmental sources and it may accept from private sources and may secure funds in any manner authorized by Chapter 471.59 of Minnesota Statutes. Area II may expend such funds pursuant to Chapter 471.59 and the provisions of this agreement.

Subdivision 8. Area II may receive, administer, and disburse any moneys authorized by Minnesota law.

Subdivision 9. Area II may adopt rules and regulations to effectuate the purposes of this agreement.

Subdivision 10. Area II may provide any participating county or any other unit of government with technical data or any other information of which Area II has knowledge which will assist the governmental unit with water related projects.

Subdivision 11. Area II may accumulate reserve funds for the purposes mentioned and may invest funds of Area II not currently needed for its operation in the manner and subject to the laws of Minnesota applicable to municipalities.

Subdivision 12. Area II may make contracts, incur expenses, and make expenditures necessary and incidental to the effectuation of these purposes and powers and may disburse therefore in the manner hereinafter provided.

Subdivision 13. Area II shall cause to be made an annual audit of the books and accounts of Area II and shall make and file a report with its participating counties at least once each year including the following information:

- a) The financial condition of Area II.
- b) The status of all Area II projects and work within the area.
- c) The business transacted by Area II in other matters which affect the interest of the counties.

Copies of said report shall be submitted to the auditor of each participating county.

Subdivision 14. Area II's books, reports, and records shall be available for and open to inspection by the participating counties at all reasonable times during normal business hours at Area II's office.

Subdivision 15. Area II may recommend changes in this agreement to the participating counties upon a two-thirds (2/3s) majority vote.

Subdivision 16. Each participating county reserves the right to conduct separate or concurrent studies of any matter under study by Area II.

IX. PROJECTS

Subdivision 1. Area II shall have no power to initiate projects or improvements unless the proposed project or improvement receives a majority vote of the Board of Directors of Area II. All such proceedings shall be in conformance with Minnesota Statutes, Chapter 103F, Sections 171-187; 471.59; and special legislation.

Subdivision 2. Area II will consult with the Minnesota Board of Water and Soil Resources, through its Chief Engineer, on the setting of project priorities and the effect of individual projects on overall State floodplain management plans.

Subdivision 3. The provisions of Minnesota Statutes, Chapter 103F, Sections 171-187, shall be adhered to when the funds provided thereunder are to be used to finance a project.

X. FINANCES

Subdivision 1. Each participant to this agreement shall cause its respective county auditor to make annual levies of *ad valorem* taxes as authorized by Minnesota law for the benefit of an association of counties.

Subdivision 2. The Board of Directors of Area II shall prepare and present at the Board's monthly meeting in May, a budget for the next fiscal year. This budget shall include monies to match the State grant monies under Minnesota Statutes Chapter 103F Sections 171-187 or other grants for projects approved by the Board of Directors. A two-thirds (2/3s) majority vote of the Board will be required to approve this budget. Each participating county shall be billed for its share of this budget as determined by the Board and included as Attachment "A" to this document.

Subdivision 3. Area II shall disburse the local matching funds for projects to the project sponsors when the project is completed to the satisfaction of the Board of Directors as recommended by Area II staff.

Subdivision 4. Such funds as Area II shall receive from any source shall be deposited in depositories selected by the Board of Directors of Area II.

Subdivision 5. Area II by its Treasurer, shall account for, administer, and disburse said funds with each expenditure in the form of a check signed by the Treasurer and other authorized and bonded signatory.

Subdivision 6. Area II may disburse project funds only for such projects or improvement for which a preliminary engineering report has been prepared and which is in conformity with the comprehensive water plan of the County within which the project lies or the overall plan of the watershed within which the project lies, if the project lies within a watershed district.

Subdivision 7. Area II may disburse funds necessary for operational expenses as well as compensation of its members and reimbursement of their expenses for Executive Board or special meetings.

XI. DURATION

Subdivision 1. Each participant to this agreement agrees to be bound by the terms of this agreement until December 31, 2023, at which time this agreement shall terminate unless renewed by the participants.

Subdivision 2. The agreement may be terminated prior to December 31, 2023, by two-thirds (2/3s) majority of the respective county boards of the participants to this agreement.

XII. DISSOLUTION

Upon dissolution of Area II, all property of Area II and monies on hand shall be disposed of in a manner consistent with Minnesota law, with the exception that any funds supplied to Area II by the Minnesota Board of Water and Soil Resources for the purpose of operating and maintaining the Area II Technical Office which have not been spent shall be returned to that body. Special funds comprised of county dollars (i.e. sinking fund, etc.) will be distributed to the member counties in the same amount of principal plus accrued interest on that principal.

Should a participating county elect to withdraw from Area II prior to dissolution or renewal of the joint powers agreement, the county will forfeit their share of divided property and collected levies to that point in time. The county will also forfeit their contribution to special funds (i.e. sinking fund, etc.) as these accounts serve designated purposes.

Should a participating county choose to not renew their membership in Area II when the Joint Powers Agreement is due for renewal, the County will forfeit its share of divided property and collected levies, however, the principal and interest that the member county has contributed to any unused special fund (i.e. sinking fund, etc.) will be returned to the departing county.

XIII. INDEMNIFICATION AND HOLD HARMLESS

Area II shall be considered a separate and distinct public entity to which the member counties have transferred all responsibility and control for actions taken pursuant to this agreement. Area II shall comply with all laws and rules that govern a public entity in the State of Minnesota and shall be entitled to the protections of Chapter 466 of Minnesota Statutes.

Area II shall fully defend, indemnify and hold harmless the member counties against all claims, losses, liability, suits, judgments, costs and expenses by reason of the action or inaction of the Board and/or its employees and/or the agents of Area II. This agreement to indemnify and hold harmless does not constitute a waiver by any participant of the limitations of liability provided under Chapter 466 of Minnesota Statutes.

To the full extent permitted by law, actions by the member counties pursuant to this agreement are intended to be and shall be construed as a “cooperative” activity and it is the intent of the member counties that they shall be deemed a “single governmental unit” for the purpose of liability, as set forth in Minnesota Statutes § 471.59, Subd. 1a(a); provided further that for purposes of that statute, each member county to this agreement expressly declines responsibility for the acts or omissions of any other member county.

The member counties to this agreement are not liable for the acts or omissions of the other member counties to this agreement except to the extent to which they have agreed in writing to be responsible for acts or omissions of the other member counties.

XIV. EFFECTIVE DATE

This agreement shall be in full force and effect upon execution by the respective governing bodies of all the undersigned participants. Upon execution of this agreement, each governing body of each participant shall furnish the names and addresses of the regular member appointed to the Board as well as the alternate appointed.

IN WITNESS WHEREOF, the undersigned counties by actions of their governing bodies, caused this agreement to be executed in accordance with the authority of Minnesota Statutes § 471.59.

BROWN COUNTY

Jeff Veerkamp, Area II delegate

Date:

COTTONWOOD COUNTY

Larry Anderson, Area II delegate

Date:

LAC QUI PARLE COUNTY

John Maatz, Area II delegate

Date:

LINCOLN COUNTY

Joe Drietz, Area II delegate

Date:

**LYON
COUNTY**

Gary Crowley, Area II delegate

Date:

**MURRAY
COUNTY**

Lori Gunnink, Area II delegate

Date:

**PIPESTONE
COUNTY**

Luke Johnson, Area II delegate

Date:

**REDWOOD
COUNTY**

Rick Wakefield, Area II delegate

Date:

APPROVED AS TO FORM
Redwood County Attorney

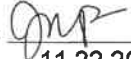
By: 
Date: 11.22.2021

**YELLOW
MEDICINE
COUNTY**

Glen Kack, Area II delegate

Date:

ATTACHMENT 'A'

COUNTY SHARES OF THE AREA II TECHNICAL OFFICE BUDGET	
Brown County	15.90%
Cottonwood County	2.76%
Lac qui Parle County	14.25%
Lincoln County	4.09%
Lyon County	27.31%
Murray County	1.37%
Pipestone County	0.70%
Redwood County	13.68%
Yellow Medicine County	19.94%
NOTE: County Share Formula = \$2,000 + (County% x (Office Budget-\$18,000))	

Redwood County Board of Commissioners

403 South Mill Street

P.O. Box 130

Redwood Falls, MN 56283

Phone: (507) 637-4016 Fax: (507) 637-4017

redwoodcounty-mn.us



PRESENT:

ABSENT:

INTRODUCED:

VOTED:

SECOND:

Aye:

Nay:

RESOLUTION

BE IT HEREBY RESOLVED, by the Board of Commissioners for Redwood County, that the 2022 property tax levies for Redwood County Funds be set as follows:

REVENUE FUND	\$8,176,720
HUMAN SERVICES FUND.....	2,890,518
PUBLIC HEALTH FUND	228,841
ROAD AND BRIDGE FUND	2,036,744
BUILDING FUND	700,000
DEBT SERVICE FUND	829,325
REGIONAL LIBRARY	109,323

BE IT FURTHER RESOLVED, that the 2022 Redwood County property tax levy be certified to the Redwood County Auditor-Treasurer at \$14,971,471.

BE IT FURTHER RESOLVED, that the 2022 Redwood County adjusted property tax levy be set at \$14,277,930, a 5.3% change from the 2021 adjusted tax levy of \$13,553,242.

ADOPTED, this 30th day of November, 2021.

Jim Salfer, Chair
Redwood County Board of Commissioners

ATTEST: Vicki Kletscher
County Administrator

1st District
RICK WAKEFIELD
P.O. Box 473
Walnut Grove, MN 56180
(507) 859-2369
Rick_W@co.redwood.mn.us

2nd District
JIM SALFER
865 Pine Street
Wabasso, MN 56293
(507) 342-2431
Jim_S2@co.redwood.mn.us

3rd District
DENNIS GROEBNER
250 Center Street
Clements, MN 56224
(507) 692-2235
Dennis_G@co.redwood.mn.us

4th District
BOB VANHEE
503 Fallwood Road
Redwood Falls, MN 56283
(507) 616-1000
Bob_V@co.redwood.mn.us

5th District
DAVE FORKRUD
P.O. Box 235
Belview, MN 56214
(507) 430-1907
Dave_F@co.redwood.mn.us

Redwood County Board of Commissioners

403 South Mill Street
P.O. Box 130
Redwood Falls, MN 56283
Phone: (507) 637-4016 Fax: (507) 637-4017
redwoodcounty-mn.us



2022 BUDGET RESOLUTION

Present:
Absent:
Introduced: Second:
Voted: Aye:
 Nay:

RESOLUTION:

WHEREAS, the Redwood County Board of Commissioners has reviewed the proposed 2022 budget with the Redwood County Department Heads to discuss budgets proposed for the staffing, supplies, and general operation of their departments during Calendar year 2021 and;

WHEREAS, the Redwood County Board of Commissioners has subsequently reviewed each of the departmental budgets in relationship to the amounts needed from the 2022 Property Tax Levy, and;

NOW, THEREFORE, BE IT RESOLVED, that the Redwood County Board of Commissioners does hereby adopt the 2022 Redwood County Budgeted Revenues and Expenditures as attached:

ADOPTED, this 30th day of November, 2021.

Jim Salfer, Chair
Redwood County Board of Commissioners

ATTEST: Vicki Knobloch
County Administrator

1st District RICK WAKEFIELD P.O. Box 473 Walnut Grove, MN 56180 (507) 859-2369 Rick_W@co.redwood.mn.us	2nd District JIM SALFER 865 Pine Street Wabasso, MN 56293 (507) 342-2431 Jim_S2@co.redwood.mn.us	3rd District DENNIS GROEBNER 250 Center Street Clements, MN 56224 (507) 692-2235 Dennis_G@co.redwood.mn.us	4th District BOB VANHEE 503 Fallwood Road Redwood Falls, MN 56283 (507) 616-1000 Bob_V@co.redwood.mn.us	5th District DAVE FORKRUD P.O. Box 235 Belview, MN 56214 (507) 430-1907 Dave_F@co.redwood.mn.us
---	---	---	--	--

BUDGETARY APPROVAL REPORT
31 - DEBT SERVICE

	<u>BUDGETED AMOUNTS</u>
REVENUE	
PROPERTY TAXES	\$ 803,617
DISPARITY REDUCTION CREDIT	2,605
MARKET VALUE CREDIT	23,103
IGR - REIM FOR SERVICES - GEN GVT	4,706
TOTAL REVENUE	\$ 834,031
EXPENDITURE	
DEBT SERVICE - PRINCIPAL	
DEBT SERVICE	\$ 1,960,000
Total DEBT SERVICE - PRINCIPAL	\$ 1,960,000
DEBT SERVICE - INTEREST	
DEBT SERVICE	\$ 332,992
Total DEBT SERVICE - INTEREST	\$ 332,992
DEBT SERVICE - ADMIN (FISCAL) CHGS	
DEBT SERVICE	\$ 1,671
Total DEBT SERVICE - ADMIN (FISCAL) CHGS	\$ 1,671
TOTAL EXPENDITURE	\$ 2,294,663
EXCESS OF REVENUES OVER (UNDER) EXPENDITURES	\$ (1,460,632)
PLANNED CHANGES TO FUND BALANCE	\$ (1,460,632)

BUDGETARY APPROVAL REPORT
22 - SOLID WASTE

	<u>BUDGETED AMOUNTS</u>
REVENUE	
SPECIAL ASSESSMENTS	\$ 621,206
IGR - REIM FOR SERVICES-SANITATION	159,376
MN DEPT OF POLLUTION CONTROL	69,692
TOTAL REVENUE	\$ 850,274
EXPENDITURE	
SOLID WASTE	
SOLID WASTE	\$ 1,900
Total SOLID WASTE	\$ 1,900
HAZARDOUS WASTE	
HAZARDOUS WASTE	\$ 1,200
Total HAZARDOUS WASTE	\$ 1,200
INTERGOVERNMENTAL - RRRSWA ASSESSMT	
RRRSWA JOINT POWERS	\$ 690,898
Total INTERGOVERNMENTAL - RRRSWA ASSESSMT	\$ 690,898
DEBT SERVICE - PRINCIPAL	
RRRSWA JOINT POWERS	\$ 1,030,000
Total DEBT SERVICE - PRINCIPAL	\$ 1,030,000
DEBT SERVICE - INTEREST	
RRRSWA JOINT POWERS	\$ 28,865
Total DEBT SERVICE - INTEREST	\$ 28,865
DEBT SERVICE - ADMIN (FISCAL) CHGS	
RRRSWA JOINT POWERS	\$ 511
Total DEBT SERVICE - ADMIN (FISCAL) CHGS	\$ 511
TOTAL EXPENDITURE	\$ 1,753,374
EXCESS OF REVENUES OVER (UNDER) EXPENDITURES	\$ (903,100)
PLANNED CHANGES TO FUND BALANCE	\$ (903,100)

*** Redwood County ***

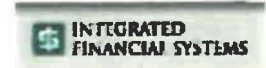

BUDGETARY APPROVAL REPORT
15 - DITCH

	<u>BUDGETED AMOUNTS</u>
REVENUE	
SPECIAL ASSESSMENTS	\$ 578,122
STATE GRANTS & CONTRIBUTIONS	750,000
FEDERAL GRANTS & CONTRIBUTIONS	3,000,000
TOTAL REVENUE	\$ 4,328,122
EXPENDITURE	
CONSERVATION	
DITCH MAINTENANCE	\$ 3,344,130
Total CONSERVATION	\$ 3,344,130
TOTAL EXPENDITURE	\$ 3,344,130
EXCESS OF REVENUES OVER (UNDER) EXPENDITURES	\$ 983,992
PLANNED CHANGES TO FUND BALANCE	\$ 983,992

BUDGETARY APPROVAL REPORT
5 - HUMAN SERVICES

	<u>BUDGETED AMOUNTS</u>
REVENUE	
PROPERTY TAXES	\$ 2,800,987
DISPARITY REDUCTION CREDIT	9,070
OUT OF HOME PLACEMENT AID	53,456
MARKET VALUE CREDIT	80,461
TOTAL REVENUE	\$ 2,943,974.
EXPENDITURE	
INTERGOVERNMENTAL - SWHHS - HS LEVY	
**** HUMAN SERVICES ****	\$ 2,943,974
Total INTERGOVERNMENTAL - SWHHS - HS LEVY	\$ 2,943,974
TOTAL EXPENDITURE	\$ 2,943,974.
EXCESS OF REVENUES OVER (UNDER) EXPENDITURES	\$
PLANNED CHANGES TO FUND BALANCE	\$

*** Redwood County ***



BUDGETARY APPROVAL REPORT
3 - ROAD AND BRIDGE

	<u>BUDGETED</u> <u>AMOUNTS</u>
HIGHWAY MAINTENANCE	\$ 209,280
Total DEBT SERVICE - INTEREST	\$ 209,280
TOTAL EXPENDITURE	\$ 19,684,633
EXCESS OF REVENUES OVER (UNDER) EXPENDITURES	\$ (5,526,551)
OTHER SOURCES(USES)	
PROCEEDS FRM SALE OF CAPITAL ASSETS	\$ 35,000
TOTAL OTHER SOURCES(USES)	\$ 35,000
PLANNED CHANGES TO FUND BALANCE	\$ (5,491,551)

BUDGETARY APPROVAL REPORT
3 - ROAD AND BRIDGE

	<u>BUDGETED AMOUNTS</u>
REVENUE	
PROPERTY TAXES	\$ 1,977,984
OTHER TAXES	1,310,000
LICENSES & PERMITS	11,000
MAINTENANCE REGULAR	2,113,607
CONSTRUCTION REGULAR	2,229,241
MAINTENANCE MUNICIPAL	246,910
CONSTRUCTION MUNICIPAL	370,365
TOWN BRIDGE	970,431
DISPARITY REDUCTION CREDIT	6,392
MARKET VALUE CREDIT	56,703
TOWN ROAD	602,755
IGR - REIM FOR SERVICES - HIGHWAY	1,663,300
HIGHWAY PLANNING AND CONSTRUCTION	2,523,344
CHARGES FOR SERVICES	6,000
EARNINGS ON INVESTMENTS	20,000
MISCELLANEOUS REVENUE	50,000
RENTAL INCOME	50
TOTAL REVENUE	\$ 14,158,082.
EXPENDITURE	
HIGHWAY ADMINISTRATION	
ROAD & BRIDGE ADMINISTRATION	\$ 584,189
Total HIGHWAY ADMINISTRATION	\$ 584,189
HIGHWAY MAINTENANCE	
HIGHWAY MAINTENANCE	\$ 3,123,052
Total HIGHWAY MAINTENANCE	\$ 3,123,052
HIGHWAY CONSTRUCTION	
HIGHWAY CONSTRUCTION & ENGINEERING	\$ 14,310,751
Total HIGHWAY CONSTRUCTION	\$ 14,310,751
HIGHWAY EQUIPMENT AND MAINT SHOPS	
EQUIPMENT MAINTENANCE & SHOP	\$ 854,606
Total HIGHWAY EQUIPMENT AND MAINT SHOPS	\$ 854,606
INTERGOVERNMENTAL - TOWN ROAD DIST	
HIGHWAY MAINTENANCE	\$ 602,755
Total INTERGOVERNMENTAL - TOWN ROAD DIST	\$ 602,755
DEBT SERVICE - INTEREST	

*** Redwood County ***

BUDGETARY APPROVAL REPORT
1 - GENERAL



	BUDGETED AMOUNTS
Total INTERGOVERNMENTAL - LIBRARY	\$ 109,323
INTERGOVERNMENTAL - SWHHS PHS LEVY COMMUNITY HEALTH	\$ 228,841
Total INTERGOVERNMENTAL - SWHHS PHS LEVY	\$ 228,841
DEBT SERVICE - PRINCIPAL WATER QUALITY LOAN PROGRAM	\$ 9,541
Total DEBT SERVICE - PRINCIPAL	\$ 9,541
DEBT SERVICE - INTEREST WATER QUALITY LOAN PROGRAM	\$ 1,081
Total DEBT SERVICE - INTEREST	\$ 1,081
TOTAL EXPENDITURE	\$ 19,714,198
EXCESS OF REVENUES OVER (UNDER) EXPENDITURES	\$ (5,928,098)
OTHER SOURCES(USES) SPECIAL ITEMS	\$ (1,665,015)
TOTAL OTHER SOURCES(USES)	\$ (1,665,015)
PLANNED CHANGES TO FUND BALANCE	\$ (7,593,113)

BUDGETARY APPROVAL REPORT
1 - GENERAL

	<u>BUDGETED AMOUNTS</u>
ASSESSOR	501,252
LICENSE CENTER	179,893
ADMINISTRATOR	412,820
ELECTIONS	93,950
COMPUTER	493,814
ATTORNEY	875,689
RECORDER	320,477
COURTHOUSE MAINTENANCE	525,856
BUILDINGS AND PLANT	7,025,000
VETERAN SERVICE OFFICER	180,345
Total GENERAL GOVERNMENT	\$ 12,946,529
PUBLIC SAFETY	
SHERIFF	\$ 4,271,238
E-911 SYSTEM	73,000
CORONER	23,000
OTHER PUBLIC SAFETY	13,000
PROBATION AND PAROLE	255,757
RESTORATIVE JUSTICE	93,923
SENTENCE TO SERVE	83,631
EMERGENCY MANAGEMENT	97,856
Total PUBLIC SAFETY	\$ 4,911,405
CULTURE & RECREATION	
MUSEUM	\$ 2,435
OTHER CULTURE & RECREATION	57,500
PARKS	145,347
MINNESOTA TRAILS	95,633
Total CULTURE & RECREATION	\$ 300,915
CONSERVATION	
AGRICULTURAL INSPECTION	\$ 318,320
EXTENSION	146,602
OTHER CONSERVATION	41,104
SOIL AND WATER CONSERVATION DISTRICT	535,818
Total CONSERVATION	\$ 1,041,844
ECONOMIC DEVELOPMENT	
OTHER ECONOMIC DEVELOPMENT	\$ 164,919
Total ECONOMIC DEVELOPMENT	\$ 164,919
INTERGOVERNMENTAL - LIBRARY	
LIBRARY	\$ 109,323

*** Redwood County ***

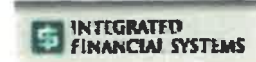

BUDGETARY APPROVAL REPORT
1 - GENERAL

	<u>BUDGETED AMOUNTS</u>
REVENUE	
PROPERTY TAXES	\$ 8,296,918
OTHER TAXES	11,000
SPECIAL ASSESSMENTS	24,877
LICENSES & PERMITS	62,700
PAYMENT IN LIEU OF TAXES	284,378
DISPARITY REDUCTION CREDIT	26,791
POLICE AID	120,000
COUNTY PROGRAM AID	893,203
E-911	173,575
MARKET VALUE CREDIT	237,670
CASINO CREDIT	70,000
IGR - REIM FOR SERVICES - PUB SFTY	140,939
LOCAL GRANTS & CONTRIBUTIONS	10,000
IGR - REIM FOR SERVICES - CONSERVTN	387,000
MN DEPT OF PUBLIC SAFETY	1,000
MN BOARD OF WATER AND SOIL RES	74,859
MN DEPT OF NATURAL RESOURCES	95,633
MN DEPT OF VETERANS AFFAIRS	10,000
MN DEPT OF PEACE OFFICERS BOARD	12,000
MN DEPT OF CORRECTIONS	60,000
FEDERAL GRANTS & CONTRIBUTIONS	1,473,298
DEPARTMENT OF JUSTICE	72,500
DEPARTMENT OF HOMELAND SECURITY	2,072
EMERGENCY MANAGEMENT PERFORMANCE	20,029
CHARGES FOR SERVICES	797,800
EARNINGS ON INVESTMENTS	23,979
MISCELLANEOUS REVENUE	151,039
RENTAL INCOME	187,840
INSURANCE DIVIDENDS	65,000
TOTAL REVENUE	\$ 13,786,100
EXPENDITURE	
GENERAL GOVERNMENT	
COMMISSIONERS	\$ 255,327
LAW LIBRARY	58,500
COUNTY ADMINISTRATION	1,597,997
AUDITOR-TREASURER	425,609

*** **Redwood County** ***
BUDGETARY APPROVAL REPORT

11-18-21
updated
INTEGRATED
FINANCIAL SYSTEMS

Budget: 2022 BUDGET (ORIGINAL) ORIG